

Fish brains: evolution and environmental relationships

K. KOTRSCHAL^{1,*}, M.J. VAN STAADEN^{2,3} and R. HUBER^{2,3}

¹*Institute of Zoology, Department of Ethology, The University of Vienna and Konrad Lorenz Forschungsstelle, A-4645 Grünau 11, Austria*

²*Institute of Zoology, Department of Physiology, The University of Graz, Universitätsplatz 2, A-8010 Graz, Austria*

³*Department of Biological Sciences, Bowling Green State University, Life Science Bldg, Bowling Green, OH 43403, USA*

Contents

Abstract	page 373
Fish brains reflect an enormous evolutionary radiation	374
Based on morphology: how conclusions on sensory orientation are reached	376
Structure of fish brains	378
Large-scale evolutionary patterns of fish brains	384
Functional diversification	386
Cyprinidae	
Gadidae	
Flatfishes	
Cichlidae and other modern perciforms	
How environments shape brains: turbidity, benthos and the pelagic realms	393
Variation of brain and senses with depth	395
Ontogenetic variation: a means of adaptation?	398
Intraspecific variation between 'adult' age classes	
Intraspecific variation within age classes	
Conclusions: where to go from here?	400
Acknowledgements	401
References	402

Abstract

Fish brains and sensory organs may vary greatly between species. With an estimated total of 25 000 species, fish represent the largest radiation of vertebrates. From the agnathans to the teleosts, they span an enormous taxonomic range and occupy virtually all aquatic habitats. This diversity offers ample opportunity to relate ecology with brains and sensory systems. In a broadly comparative approach emphasizing teleosts, we surveyed 'classical' and more recent contributions on fish brains in search of evolutionary and ecological conditions of central nervous system diversification. By qualitatively and quantitatively

*Corresponding author. E-mail: klf.gruenau@telecom.at

comparing closely related species from different habitats, particularly cyprinids and African cichlids, we scanned for patterns of divergence. We examined convergence by comparing distantly related species from similar habitats, intertidal and deep-sea. In particular, we asked how habitats relate to the relative importance of different sensory faculties. Most fishes are predominantly visually orientated. In addition, lateral line and hearing are highly developed in epi- and mesopelagic species as well as in the Antarctic notothenoids. In bathypelagics, brain size and the lobes for vision and taste are greatly reduced. Towards shallow water and deep-sea benthic habitats, chemosenses increase in importance and vision may be reduced, particularly in turbid environments. Shallow tropical marine and freshwater reefs (African lakes) enhance visual predominance and appear to exert a considerable selection pressure towards increased size of the (non-olfactory)telencephalon. The development of cognitive skills (spatial learning, problem solving) in fish seems to be associated with visual orientation and well-structured habitats.

Keywords: acoustico-lateralis lobes, bulbus olfactorius, ecomorphology, lobus facialis, lobus vagus, tectum opticum

Fish brains reflect an enormous evolutionary radiation

Faculties for sensory perception, central processing, and behavioural responses undoubtedly reside primarily within an organism's nervous system. In the course of evolution, peripheral and central components of nervous systems have flourished into a functional diversity of structures, shapes and sizes rivalled by few other organs. A chief aim of evolutionary neurobiology and ecomorphology is to reveal whether, and in what way, physical brains reflect sensory orientation, cognitive potential, and motor abilities. Viewed within a phylogenetic context, a study of this diversity can uncover how brains have responded to the requirements of disparate habitats, ecologies and behavioural needs. Less than a century of ecomorphological research (Herrick, 1902, 1906, Evans, 1931) has produced a large empirical database for fish brains which we attempt to synthesize in the present review.

Fish contain more than half of all known vertebrate taxa with an estimated total of 25 000 species, most of these modern teleosts (Nelson, 1994). Embodying more than 400 million years of vertebrate evolution, taxonomic distance within this group is immense, greatly exceeding, for example, that between frog and human (Romer, 1959). Fish occupy virtually every aquatic habitat, from tropical reefs to abyssal depths; some have even adopted amphibian-like lifestyles. Associated ecological and behavioural demands have, against the backgrounds of the constructional constraints of the nervous system and evolutionary inertia, fashioned basic brain designs into a vast number of individual variations on the theme (Nieuwenhuys *et al.*, 1998).

Over the years, research has diversified, in a fractal sense, from wider to more narrow taxonomic units, and has progressed from a search for basic ecological correlates to ever finer subdivision of niche parameters. Recent papers based on a combination of quantitative techniques and the applications of multivariate statistical designs have illuminated the characteristics of evolutionary trends in a variety of taxa.

In short, both ecology and phylogenetic distance account for significant amounts of brain variability. For example, when comparing the brains of sharks and teleosts (Fig. 1), effects of evolutionary history prevail, whereas nested downwards, comparisons within the latter taxon (i.e. the ostariophysans, the cyprinids, and within the abramine cyprinids) will increasingly pinpoint ecology as the major covariant of morphology.

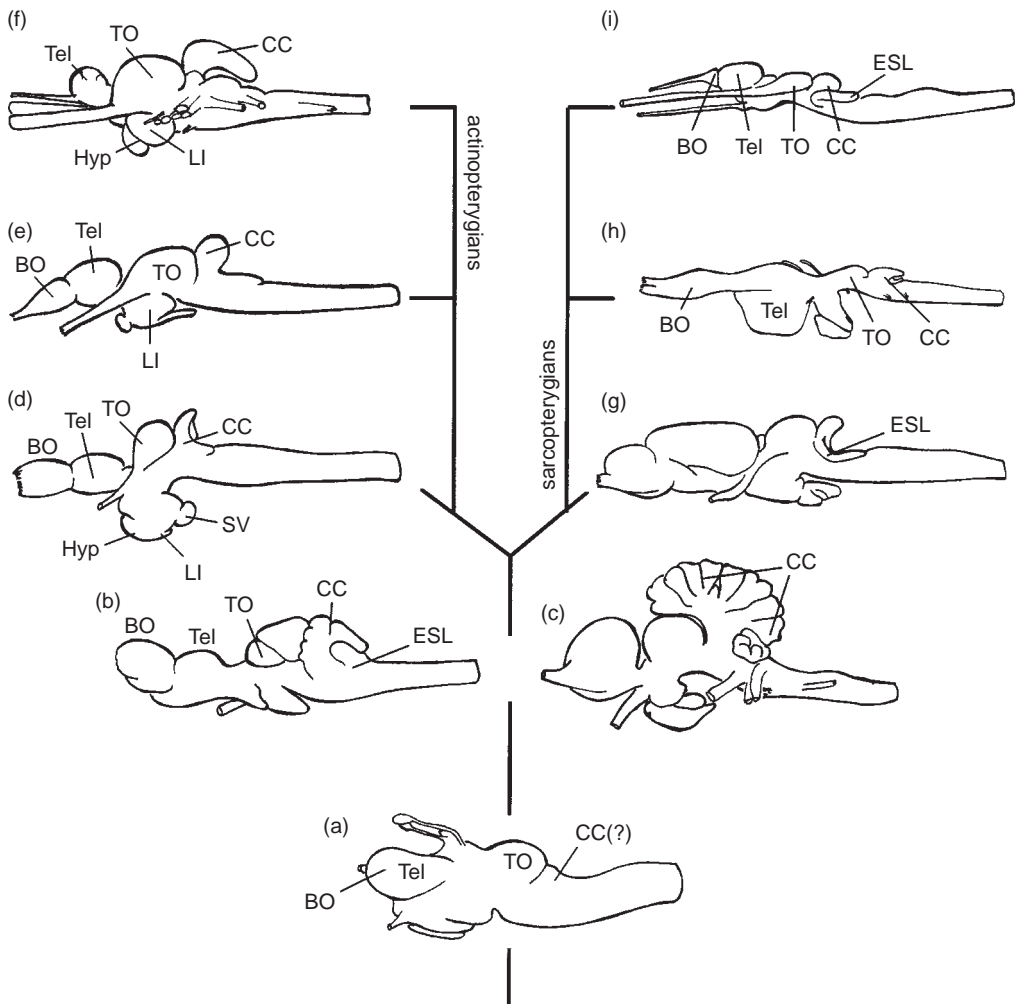

Fig. 1. Representative brains showing variation between major taxonomic groups of fish. Forebrains are evaginated in the lamprey (a: *Petromyzon*), in the elasmobranchs (b: *Acanthias*, c: *Cetorhinus*), lungfish (h: *Ceratodus*) and the coelacanth (i: *Latimeria*), but everted in the actinopterygian line, such as in the bichirs (g: *Calamoichthys*), sturgeons and neopterygians (d: *Acipenser*, e: *Amia*, f: *Gadus*). BO, bulbus olfactorius; CC, corpus cerebelli; ESL, electrosensory lobe; Hyp, hypophysis; LI, lobus inferior; SV, saccus vasculosus; Tel, telencephalon; TO, tectum opticum. Brains redrawn after Holmgren and van der Horst (1925), Senn (1976), Romer and Parsons (1977), Northcutt *et al.* (1978), Nieuwenhuys (1983), Kruska (1988) and Bone *et al.* (1995), not to scale.

In our attempt to identify and characterize forces that effectively shape the brains of fishes, we first strive to put the basic teleost brain in perspective with respect to its agnathan and lower gnathostome roots. Coverage of sub-teleosts will necessarily remain sketchy as many of these groups either have only a few species available for comparison or, where there are numerous species, such as in the elasmobranchs, adequate comparative coverage is still lacking. We then identify the prominent sources of variation present within different teleost subgroups. Because this evidence is overwhelmingly correlative, we can only speculate about the causative forces involved. Towards this goal, we will explore divergence of brain structure within closely related taxa with contrasting lifestyle. We also will search for convergences in the brains of different taxonomic groups so as to suggest potentially specific selection pressures present in major aquatic habitats, such as shallow or deep pelagic or benthos.

Based on morphology: how conclusions on sensory orientation are reached

The present approach rests on the assumptions that the relative size of peripheral organs scales positively with that of the related brain centres, and that both are a measure of the relative importance of a particular sensory faculty in the sensory orientation of individuals, life-history stages or species. The available literature indicates that these assumptions are realistic, particularly when focusing on closely related taxa (Evans, 1940; Clutton-Brock and Harvey, 1980; Jolicoeur *et al.*, 1984; Douglas and Hawryshyn, 1990; Ridet and Bauchot, 1990a, b; Kotrschal and Palzenberger, 1992; Eastman and Lannoo, 1995; van Staaden *et al.*, 1995). It appears that changes in demand predominantly alter the number and sizes of component elements rather than their connectivity (Kotrschal and Junger, 1988; Huber and Rylander, 1992), making the relative size of brain areas a reliable predictor of their relative importance (Kishida, 1979; Kotrschal and Palzenberger, 1992; Schellart, 1992; Schellart and Prins, 1993).

Quantitative comparative ecomorphology (definition: Motta and Kotrschal, 1992) of brains relies on the measurement of brain regions in a number of closely related species, either from the exterior (Huber *et al.*, 1997) or from histological sections (Kotrschal and Palzenberger, 1992). Absolute sizes can then be made comparable between individuals and species of different body sizes using one of several techniques (Sneath and Sokal, 1973). Multivariate methods have proven particularly useful for exploring large data sets and extracting significant patterns of brain structure where many measures are involved and correlations among them are often high.

The prospect of using reconstructed phylogenies to test hypotheses of adaptation is

Fig. 2. Comparison between a perciform and a cypriniform brain: (a) blenny, *Blennius incognitus*; (b) roach, *Rutilus rutilus*. Lateral views in the middle of the page, representative cross sections at levels indicated by the vertical lines at top and bottom of page. Note small bulbus olfactorius, but large telencephalon, tectum opticum and corpus cerebelli in the blenny. In the roach, the olfactory bulb is remote from the telencephalon, and the somatosensory (taste) lobes of the brainstem, lobus facialis and lobus vagus are large. BO, bulbus olfactorius; CAC, central acoustic area; CC, corpus cerebelli; CrC, crista cerebellaris; EG, eminentia granularis; Hyp, hypophysis; LF, lobus facialis; LI, lobus inferior; LV, lobus vagus; MT, mesencephalic tegmentum; MY, myelencephalon; SV, saccus vasculosus; Tel, telencephalon; TL, torus longitudinalis; TO, tectum opticum; TrO, tractus olfactorius; TS, torus semicircularis; VC, valvula cerebelli.

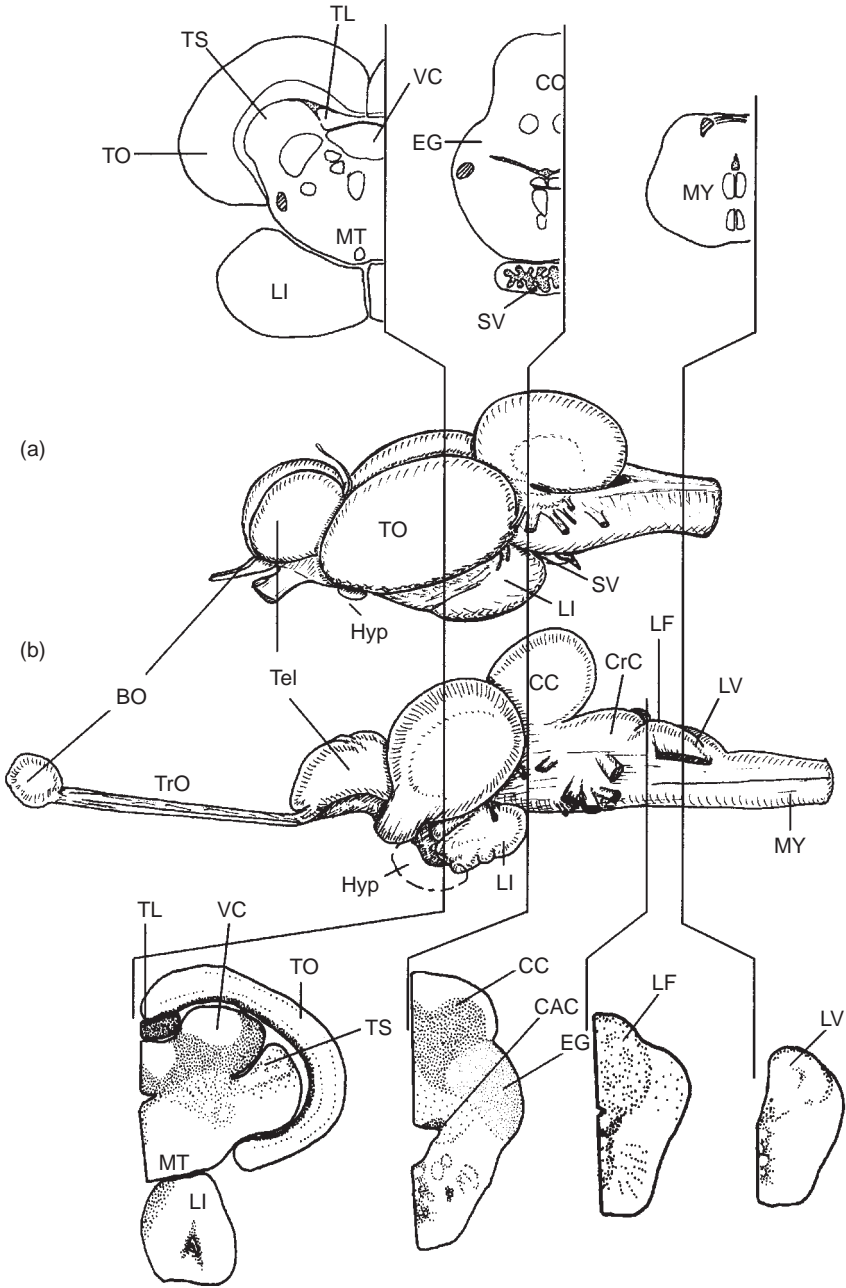

an exciting one and there is little doubt that improved phylogenetic information allows stronger inferences to be made from comparative studies (Nee *et al.*, 1996). This is true from both biological and statistical perspectives; a phylogenetic perspective allows one to infer patterns and processes of character evolution from patterns observed in extant

species, while transforming comparative data so that they do not violate the assumptions of standard statistical analysis, i.e. the 'effective sample size' problem. However, it is also true that homoplasies and temporal variation in selective environments can substantially constrain the reliability with which ancestral character states and selective environments can be inferred (Frumhoff and Reeve, 1994). We therefore resisted the temptation to attempt a statistical analysis in the present review in favour of delineating general trends from the array of recent quantitative studies. We believe this is a necessary first step in generating testable hypotheses. The time is now right to extend this inherently descriptive approach to include an explicitly phylogenetic perspective. African cichlids, for which extensive molecular phylogenies are now available (Meyer, 1993), constitute one of the most promising groups for such analysis and are the focus of ongoing study.

Structure of fish brains

Fish brains exhibit the serial arrangement of subdivisions typical of most vertebrates (Figs 1, 2). With few pathways descending from the brain, the motor system resides largely within the spinal cord (Davis and Northcutt, 1983; Northcutt and Davis, 1983; Nieuwenhuys *et al.*, 1998) with the exception of several prominent brainstem reflexes (e.g. the Mauthner neuron system for escape). Somatosensory information reaches the brain primarily via specialized cranial nerves, notably trigeminus (V), facialis (VII), vagus (X) and three lateral line nerves, two anterior and one posterior, rather than through ascending fibre systems of the spinal cord.

Rostrally, the spinal cord merges with the brain stem and tegmentum of mesencephalon and diencephalon (Fig. 2). The cerebellum arises from its rostral roof and a pair of optic lobes (tectum opticum) cap the mesencephalon. The telencephalon consists of paired cerebral hemispheres with olfactory bulbs attached to the rostral hemispheres in most fish.

The braincase may constrain brain size only in some of the smallest representatives of modern, perciform teleosts. In most fishes, however, the brain is considerably smaller than the space available and in some cases may occupy only about 6% of the brain cavity in an elasmobranch (Kruska, 1988). The excess space is commonly filled with lymphatic, fatty tissue (Fig. 3). Most neurons are relatively large in agnathans, sarcopterygians, chondrosteans and elasmobranchs, and are small in teleosts. The observed decrease in cell size probably arises from size constraints during larval life, when, at only a few mm in length, these animals are the smallest fully functional vertebrates (Fernald, 1984; Kotrschal *et al.*, 1990). Intergroup comparisons commonly based on encephalization indices (indicating the size of the brain relative to body size) may thus be misleading when these exclude, for example, the actual number of neurons and the connections between them (Pagel and Harvey, 1989).

Brains scale negatively allometrically with body size (Northcutt *et al.*, 1978), with ontogenetically and phylogenetically small fish tending to have relatively large brains and vice versa (Bauchot *et al.*, 1982; Brandstätter and Kotrschal, 1990; Ridet and Bauchot, 1990a). Although encephalization indices demand careful interpretation, there appears to be at least a coarse trend towards increases in brain size during phylogenetic development. Agnathans, for example, feature some of the relatively smallest brains, whereas those of perciforms are among the largest.

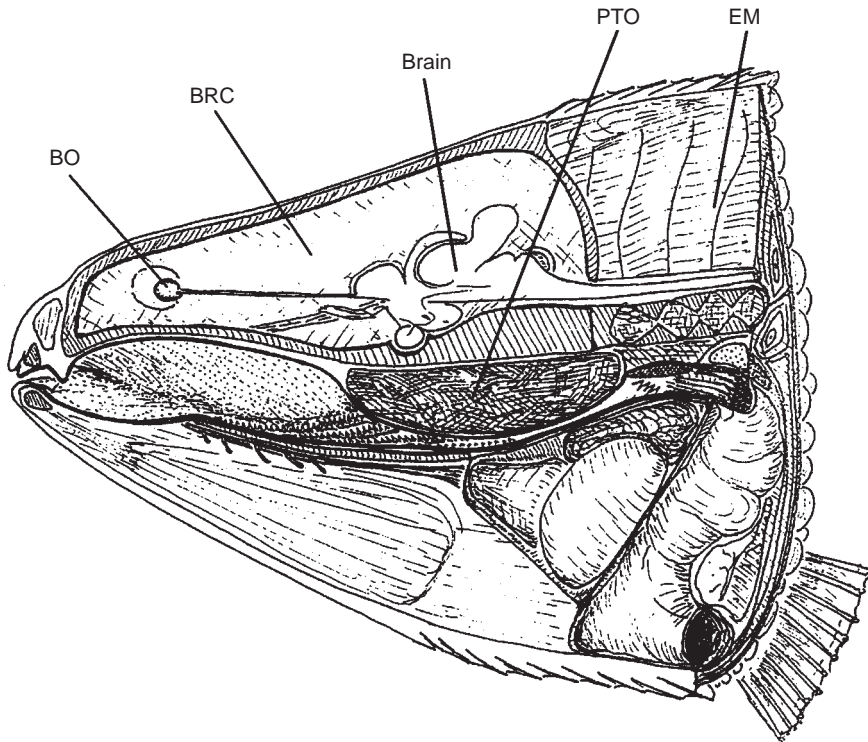

Fig. 3. Mid-sagittal section through the head of a common carp of approx. 20 cm standard length. The spacious braincase is filled with lymphatic fatty tissue and is only partially occupied by the brain. The larger the fish, the proportionally smaller its brain. Note also the sorting apparatus (palatal organ) in the posterior oropharyngeal cavity, which is represented in the vagal lobe (Figs 2, 5). BO, bulbus olfactorius; BRC, braincase; EM, epaxial musculature; PTO, palatal organ (sorting apparatus innervated from the vagal nerve). The view of the pharyngeal teeth on the posterior gill arch is obstructed by the tongue-like PTO.

The *brain stem* houses primary representation centres for all somatosensory faculties except olfaction and vision, and features a degree of variability matched by few other brain divisions. In unspecialized, evolutionary ‘mainstream’ fishes, from agnathans to basic teleosts, neuronal groups are arranged in four horizontal columns with sensory components of cranial nerves IV–XII and of two rostral and one caudal lateral line nerves terminating in the two dorsal most columns, while motor fibres originate from ventrally located centres (Allis, 1897; Johnston, 1901; Herrick, 1906; Ariens Kappers *et al.*, 1967; Northcutt, 1996; Webb and Northcutt, 1997). The dorsal, sensory columns along the wall of the fourth ventricle, for example, process the senses of hearing, of lateral line and of taste. Such somatotopic arrangement may facilitate the formation of short-loop reflexes (Kanwal and Finger, 1992), and of sensomotory specializations such as the cyprinid palatal organ (Fig. 3; Finger, 1987; Sibbing and Uribe, 1985; Sibbing, 1991). One additional, dorsorostral column is found in fishes with an ability to process electrosensory information (e.g. in *Calamoichthys* and *Latimeria*, Fig. 1; Heiligenberg,

1988; Zakon, 1988). The roof of the fourth ventricle is formed by a chorioid plexus with varying degrees of differentiation (Weiger *et al.*, 1988).

Hypertrophy of areas within the dorsal column is commonly associated with sensory specializations and these may form prominent bulges as in many cyprinids and gadids (Evans, 1940; Figs 2, 4, 5). In addition to several ascending and descending fibre systems, the brain stem houses the reticular formation, a ventrally located system for basic maintenance and life support (Davis and Northcutt, 1983).

The mesencephalic and diencephalic *tegmentum* (Fig. 1) continues rostrally to the brain stem with connective and integrative systems for brain structures arising from its roof – the cerebellum, the tectum opticum and the forebrain (Davis and Northcutt, 1983). Brain stem and tegmentum are continuous with each other and the sub-cerebellar secondary gustatory nucleus may serve as an arbitrary border. In a rostro-caudal direction, the tegmental third ventricle changes from a slit-like gap to a narrow channel before opening into the fourth ventricle (Fig. 4). Several structures form as extensions to this ventricle. The inferior lobes (Figs. 1, 2, 4, 5) of the hypothalamus are paired, ventral diencephalic hemispheres which serve as multimodal integration centres. As in all vertebrates, the hypothalamic tegmentum serves to convert sensory inputs into hormonal and behavioural responses. The saccus vasculosus is a circumventricular organ of still unknown function, caudal to the hypophyseal stalk and present throughout a wide phylogenetic range of fish. It contains cerebrospinal fluid-contacting neurons and distinctive ependyma, i.e. crown cells, which, in sturgeons, cover the entire floor of the third ventricle (Kotrschal *et al.*, 1983). The neurohypophysis serves as a central humoral command unit of physiology and behaviour, and is itself controlled by the hypothalamus. Dorsally, the chorioid plexus of the third ventricle forms several extensions, such as the saccus dorsalis with its light-sensitive and endocrine epiphysis or other circumventricular organs (Leonhardt, 1980; Vigh-Teichmann and Vigh, 1983).

The *cerebellum* varies in extent from a small, amphibian-like ridge in ancestral or sedentary, benthic fishes, to a prominent structure in most modern teleosts (Figs 1, 2). Although relatively large in pelagic sharks or swiftly manoeuvring teleosts, it is not necessarily characteristic for a pelagic lifestyle *per se* (see below). Also, in many modern electrosensitive fishes, this structure becomes massively enlarged and may even cover the entire surface of the brain as in *Gnathonemus* (Maler *et al.*, 1991). Various subareas within this structure are likely to serve diverse functions (Finger, 1983a).

Corpus and valvula cerebelli, the latter as a rostral extension beneath the optic tectum, are intimately connected and appear to play roles in spatial orientation, proprioception, motor coordination, and eye movement. The central acoustic area

Fig. 4. Mid-sagittal sections through the brains of representative actinopterygian groups: (a) Teleostei: *Blennius*; (b) Teleostei: *Tinca*; (c) Teleostei: *Salmo*; (d) Holostei: *Amia*; (e) Chondrostei: *Acipenser*. Ventricular surfaces shaded. Except for the bulbus olfactorius, brain tissue increases in relative volume towards the modern teleosts (e–a, for example, compare the development of the infundibular lobes), at the expense of ventricular spaces and the plexus II and IV. All the actinopterygian forebrains are everted, the olfactory bulbs of the lower actinopterygians are evaginated and contain a ventricle in *Acipenser* and *Amia*. BO, bulbus olfactorius; CA, commissura anterior; CC, corpus cerebelli; Ep, epiphysis; Hyp, hypophysis; LF, lobus facialis; LI, lobus inferior; SV, saccus vasculosus; Tel, telencephalon; TO, tectum opticum; TrO, tractus opticus; VC, valvula cerebelli. VI–V.IV: Ventricular spaces 1–4.

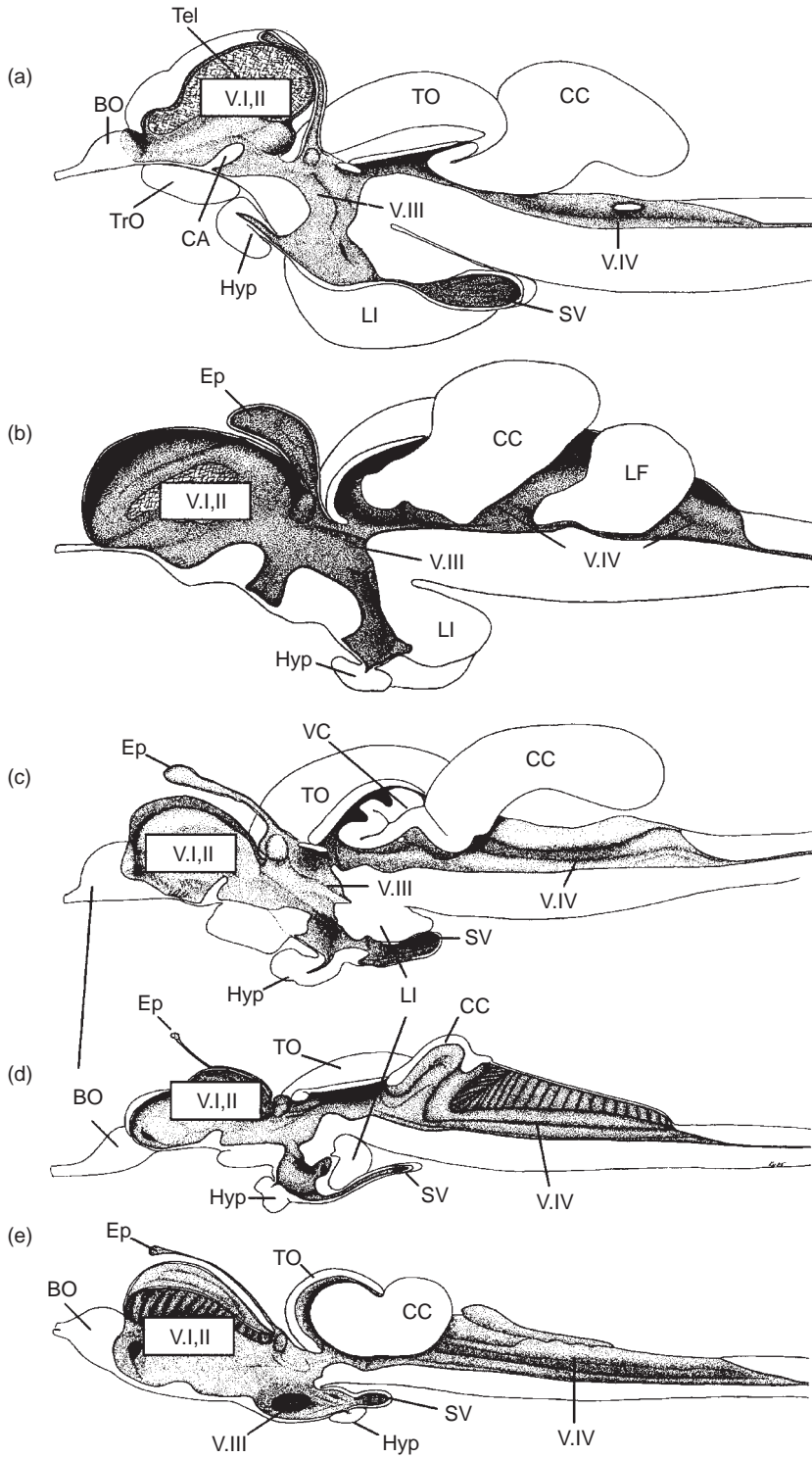

(Evans, 1940; Figs 2, 5; pars medio-distalis, Finger, 1983a) forms as a granular area at the ventral cerebellar surface and varies in size with the development of the peripheral hearing apparatus (Evans, 1940, Popper and Fay, 1993). Inputs from the inner ear and from lateral line fibres terminate at the eminentia granularis, a parvocellular area on both sides of the lateral corpus. The crista cerebelli, caudal and in continuation with the molecular layer of the corpus, predominantly processes lateral line input (Davis and Northcutt, 1983).

Arising from the mesencephalic roof, the *tectum opticum* consists of paired, dorsal hemispheres, separated from the tegmentum by ventricular spaces (Figs 1, 2, 5). This structure, exhibiting prominent layering in cross section (Kishida, 1979; Kotrschal and Junger, 1988; Guthrie, 1990), receives projections from contralateral, retinal ganglion cells, and participates in significant bidirectional communication with the brain stem (Davis and Northcutt, 1983). Tectal development varies closely with a variety of peripheral visual structures but is still present in ontogenetically or phylogenetically blind fishes (Winkelmann and Winkelmann, 1968; see below).

The *retina* forms as part of the diencephalon and a considerable amount of information is available on its variability in the context of phylogeny (Engström, 1960, 1961, 1963), ontogeny (Fernald 1984, 1985; Kotrschal *et al.*, 1990), or ecology and lifestyle (Ahlbert, 1968; Loew and Lythgoe, 1978; Levine and MacNicol, 1979; van der Meer and Anker, 1984; Ali and Klyne, 1985; Fernald, 1985; Collin and Pettigrew, 1988a,b; Lythgoe, 1988; Kotrschal *et al.*, 1990; Zaunreiter *et al.*, 1991; Huber and Rylander, 1992; Schellart and Prins, 1993). Space limitations preclude an exhaustive treatment of the retina in the present review.

Below the optic lobes, the *torus longitudinalis* extends into the sub-tectal ventricle as a pair of longitudinal cylinders. Its presumed functions include postural control, detection of luminance levels, monitoring of saccadic movement (Banarescu, 1956; Ariens Kappers *et al.*, 1967; Ito and Kishida, 1978; Northmore *et al.*, 1983). Also, it has a role as premotor centre between telencephalon and brain stem (Wullimann, 1994).

Fig. 5. Anatomy of the brain of roach (*Rutilus rutilus*) as an example of a generalized cyprinid. (a) Representative cross sections at levels indicated by the vertical lines; (b) top view; (c) lateral view. Note the rostral position of the olfactory bulbs (BO), which are attached to the nasal cavity and connected with the telencephalon via the medial and lateral tractus olfactorius. Specific for cyprinids is the brain stem with a central facial lobe (LF, the 'tuberculum impar'), which is the primary termination area of the taste bud input from the body surface. The LF is embedded between the two hemispheres of the vagal lobe (LV), which receives taste and tactile input from the oropharyngeal cavity (Fig. 3). The cerebellar crest (CrC), rostral to the LV, caps the nucleus medius, which receives primary sensory input from the lateral line. Still further rostral, at the lateral cerebellum (CC), the eminentia granularis (EG) and the central acoustic area (CAC also: medial pars distalis of the cerebellum) are primarily concerned with the processing of acoustic input. BO, bulbus olfactorius; CA, commissura anterior; CAC, central acoustic area; CC, corpus cerebelli; Cer, cerebellum; CrC, crista cerebellaris; EG, eminentia granularis; Hyp, hypophysis; LI, lobus inferior; MT, mesencephalic tegmentum; MY, myelencephalon; N.VII, nervus facialis; N.X, nervus vagus; SV, saccus vasculosus; Tel, telencephalon; TL, torus longitudinalis; TO, tectum opticum; TrO, tractus olfactorius; TrOpt, tractus opticus; TS, torus semicircularis; VC, valvula cerebelli. Redrawn, from Brandstätter and Kotrschal (1990).

The *telencephalon* arises from the rostral portion of the embryonic neural tube forming two hemispheres (Meader, 1939; Figs 1, 2, 5). Telencephalic hemispheres in more ancestral taxa of agnathans, elasmobranchs and sarcopterygians develop by evagination from the lateral walls (Nieuwenhuys, 1982) and contain a ventricle. In contrast, the actinopterygian forebrain forms by eversion of the dorsal walls of the embryonic neural tube. Hemispheres are therefore solid, and a T-shaped ventricle separates the two halves up to the dorsolateral surface. Centrally, the two hemispheres are closely attached to each other and may even be coalescent (Fig. 4b) or fused. In addition to secondary olfactory fibres which terminate throughout the entire structure, virtually all sensory modalities project to its dorsal portion through lemniscal pathways (Finger, 1980) and hypothalamic as well as primary olfactory input is received at the

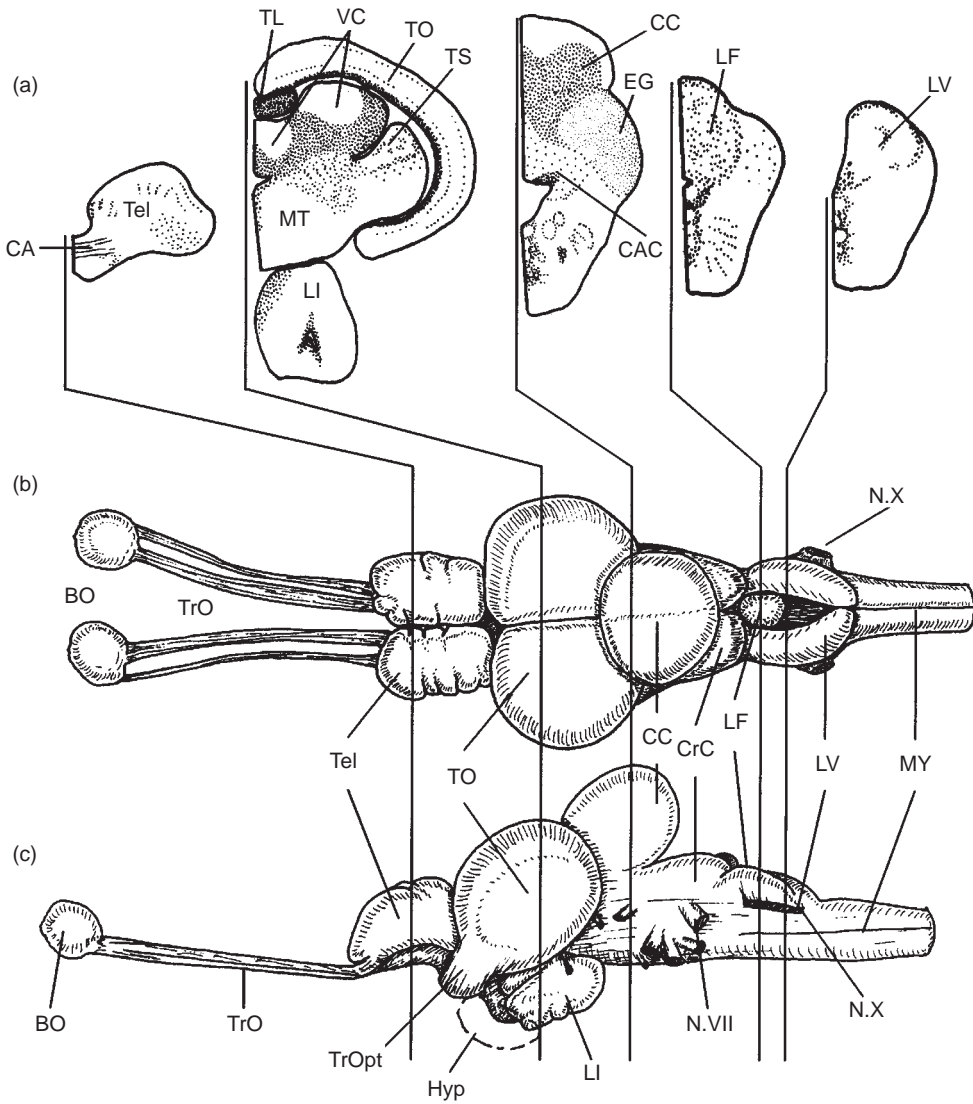

ventral forebrain. The latter also contains the commissura anterior (Figs 4, 5) with a peduncle of decussating fibre tracts for a two-way flow of information between telencephalon and diencephalon as well as intratelencephalic fibres. Fish that had had their forebrains ablated, fed, grew and behaved normally in most respects, but exhibited significantly diminished rates of learning (Rooney and Laming, 1988; Laming and McKinney, 1990) and were unable to perform more complex social tasks.

The *bulbus olfactorius* of all fishes evaginates from the rostral tip of the embryonic neural tube. Its ventricles are secondarily reduced or absent in advanced actinopterygians (Fig. 4). Primary fibres from the olfactory mucosa terminate within glomerular structures of the olfactory-bulb neuropil. Large projection neurons, mitral cells and tuft cells, project into telencephalon and diencephalon via medial and lateral olfactory tracts (Fig. 5; Finger, 1988). In most species, bulbs remain attached to the rostral telencephalon (Figs 1–10) but are attached to the olfactory mucosa in ostariophysean teleosts (Fig. 2). In gadids, olfactory bulbs are located either half-way between forebrain and olfactory mucosa or even closer towards the latter (Evans, 1935, 1940; Okamura, 1966).

Perikarya of the *terminal nerve*, located at the junction between olfactory bulbs and telencephalon, send processes into the olfactory mucosa, the diencephalon, and indeed into most brain areas including the retina (Demski and Schwanzel-Fukuda, 1987; Stell *et al.*, 1987; von Bartheld and Meyer, 1988; Nieuwenhuys *et al.*, 1998). The function of this olfacto-retinalis system which contains GnRH (gonadotrophin releasing hormone) is still unclear.

Large-scale evolutionary patterns of fish brains

Morphological diversification in fish is high compared with that of other vertebrates, even if we account for differences in taxonomic range (Stephan, 1967; Jolicœur *et al.*, 1984). This may, at least partly, be explained by a higher number of potential sensory modalities in aquatic environments, due to the physical properties of water, compared with that available to terrestrial animals (Atema *et al.*, 1988). Aside from vision, olfaction and hearing, fish exhibit an extensive array of additional 'aquatic' senses including mechanosensory lateral line, different schemes for external taste (taste buds and solitary chemosensory cells) and a range of electroreceptor systems. Not surprisingly, brain variation prominently reflects this wealth of sensory mechanisms. Compared with mammals, brain structure in fish is more likely to escape a variety of spatial and developmental constraints. In fish, where neurogenesis continues largely throughout life, allometries may account for lifelong changes in brain morphology (Brandstätter and Kotrschal, 1989, 1990).

Present-day *agnathans*, such as lampreys and hagfishes, are fairly monomorphic relict species out of a considerable palaeozoic diversity and represent only a small fraction of this fauna. An early radiation of brains presumably existed in conodont evolution (Aldridge and Purnell, 1996), but is probably forever lost to us owing to poor fossilization.

Similarities between lampreys and hagfishes feature well-developed olfactory bulbs and a prominent brain stem, whereas telencephalon and optic tecta remain relatively small (Fig. 1). The small cerebellum of lampreys is most likely homologous to the eminentia granularis rather than to the corpus cerebelli of gnathostomes (Northcutt, 1996). In hagfishes, a cerebellum is virtually absent and third and fourth ventricles lack

chorioid covers. Differences in sensory orientation and brain morphology between these two groups are more likely associated with differences in habitat than in phylogeny (Braun, 1996). Vision and lateral line inputs predominate in shallow-water lampreys, while the brains of mesobenthic hagfishes are relatively smaller with an increased reliance on chemical and tactile senses. Parallel to the patterns of brain structure and sensory emphasis in deep-sea benthic fishes (see below), the brains of hagfishes may be secondarily reduced and thus highly derived rather than primitive (Wicht, 1996).

Chondrichthyes, including sharks, rays and chimaerans, exhibit relatively large brains (Fig. 1) with spacious ventricles extending even into the cerebellum. Olfactory bulbs are well developed in benthic sharks, whereas pelagic species generally exhibit large cerebella instead (Kruska, 1988). Conspicuous thickenings of the dorsal rhombencephalic wall result from the prominent electrosensory modality in this group. Chimaeran brains closely resemble those of sharks except for an elongated telencephalic stalk when massive eyeballs displace the Telencephalon–olfactory bulb complex rostrally.

Sarcopterygian brains (lungfish and coelacanth) more closely resemble the general design of salamanders than that of fish (Fig. 1). Brains in this group are elongated with large ventricles, and a small cerebellum is barely visible from the exterior. Forebrain ventricles contain a chorioid plexus similar to that of tetrapods. The optic tectum is fused medially in lungfish, and the myelencephalon is pronounced in all species with longitudinally enlarged columns for electrosensory processing. The coelacanth *Latimeria*, with its relatively small brain (Fig. 1), is placed more closely within the amphibian range rather than with actinopterygians (Northcutt *et al.*, 1978). Its corpus cerebelli is larger than in extant amphibians and a prominent auricular component most likely relates to the processing of the electrosensory input. The paired optic tecta are relatively small and, unlike other vertebrates, its pituitary projects far rostrally.

The brain of *polypteriform chondrosteans*, i.e. bichirs, exhibits a combination of sarcopterygian and amphibian-like features along with the more actinopterygian characteristics of a partially evaginated and everted forebrain (Fig. 1). Telencephalon, tectum opticum and cerebellum with auricular components exceed those of sarcopterygians in size. Olfactory bulbs are large in nocturnal, eel-like *Calamoichthys* compared with diurnal, more visually orientated *Erpetoichthys* (Senn, 1976; Nieuwenhuys, 1983). A more quantitative analysis correlating brain morphology with environmental variables is precluded by the small number of extant species.

Several trends in brain evolution are evident within the *actinopterygian* radiations of chondrosteian and neopterygian fishes (Figs 1, 2, 4). In general, dorsal components of the brain progressively enlarge while ventricular spaces and associated chorioid covers tend to decrease in size (Gage, 1893; Ridet, 1975; Ridet and Bauchot, 1990a, b). Somato- and viscerosensory columns of the brain stem are initially continuous but become increasingly fragmented into areas associated with individual cranial nerves, particularly the lateral line nerves and nerves V, VII, IX and X (Figs 4, 5). General levels of encephalization, as well as the size of hypothalamic inferior lobes, increase towards the teleosts and within teleosts towards the perciforms (Kassem *et al.*, 1989; Ridet and Bauchot, 1990a, b). Forebrain eversion is least pronounced in chondrosteans and greatest in the teleosts, with holosteans (the semionotiform and amiiform neopterygians) being intermediate (Fig. 1; Nieuwenhuys, 1982).

Teleosts exhibit enormous heterogeneity in brain morphology (e.g. Burr, 1928), but also share a variety of features (Ito, 1978; Senn, 1985) which are considered advanced

compared with lower actinopterygians (Figs 1, 4). These include narrow ventricular spaces and a brain derived from a dense mass of embryonic cells (Ridet, 1975) rather than from a thin-walled neural tube as in most other vertebrates. The telencephalon is widely everted (Figs 2, 5) and covered by a thin tela chorioidea, consisting of brain ependyma and connective tissue. Comparison of more ancestral teleosts (e.g. elopomorphs, ostariophysans) with more advanced representatives (e.g. percomorphs) (Figs 2, 4) reveals a shift of brain mass from primary sensory areas towards higher-order integration centres.

Functional diversification

If brains are surveyed across distant taxa (above, Figs 1, 4), the observed variation appears to be mainly a matter of taxonomic distance and, hence, evolutionary history. However, surveys within speciose teleost families, such as cyprinids, gadids, cichlids and others, reveal that brains may also relate to a variety of ecological and behavioural parameters, varying around a generalized, family-typic brain shape. Moreover, comparisons across families demonstrate that similar environments often lead to similar solutions (Figs 6–9), although the details may differ according to evolutionary history. The groups also differ prominently with regard to which specific brain parts are shaped and reconstructed the most. For example, whereas primary sensory areas exhibit the highest degree of variability in carps, cods and notothenoids (Huber and Rylander, 1992; Kotrschal and Palzenberger, 1992; Eastman and Lannoo, 1995), the major source of variation in African cichlids is contained in size and shape of the forebrain (van Staaden *et al.*, 1995).

CYPRINIDAE

Carp-like fishes, the largest teleost family in Northern Hemisphere fresh waters (Winfield and Nelson, 1991), have been researched extensively with respect to brain ecomorphology. Their external taste system is well developed (Herrick, 1902; Gomahr *et al.*, 1992). The generalized roach (*Rutilus rutilus*, Kotrschal and Junger, 1988; Brandstätter and Kotrschal, 1989, 1990; Kotrschal *et al.*, 1991) demonstrates the family-typic brain pattern (Fig. 5). Olfactory bulbs are attached to the olfactory mucosa rather than to the telencephalon. Target areas for facial and vagal taste fibres form distinct bulges within the dorsal brain stem. The facial lobe (VII) emerges from the fourth ventricle as a singular, centrally fused lobe, termed the tuberculum impar. This structure is particularly large in fish with a wealth of external taste buds such as those found on barbels. The vagal lobe is a pair of dorsocaudal ridges along the fourth ventricle receiving tactile/chemosensory fibres from the palatal organ in the dorsal, posterior pharyngeal region. It serves in sensory integration of the palatal organ (Fig. 3; Finger, 1987) when food items are concentrated prior to mastication by the pharyngeal jaws (Sibbing and Uribe, 1985; Sibbing, 1991; Lamb and Finger, 1995; Osse *et al.*, 1997). Palatal organ and vagal lobes are generally well developed in benthivorous species where barbels are reduced or lacking. In these species, presumably, a decision on palatability of food is reached after the items have been taken up into the mouth cavity. Taste lobes show considerable interspecific variability in size (Huber and Rylander, 1992; Kotrschal and Palzenberger, 1992; Figs 6, 9).

Although small invertebrates represent the dominant dietary component in cyprinid feeding, some species are herbivorous or feed on detritus (for instance carp, or nase,

Chondrostoma nasus; Schiemer, 1985, 1988), others are specialized planktivores (bleak, *Alburnus alburnus*, or sabre carp, *Pelecus cultratus*) and, as a curiosity within the group, the asp (*Aspius aspius*) is a piscivore.

Herrick (1902) distinguished between “skin tasters” featuring prominent facial lobes and “mouth tasters” where vagal lobes dominate. Evans (1940) refined this picture into several groups of benthivorous species extracting their diet from sediment with well-developed palatal organs (Fig. 3) and vagal lobes e.g. common carp (*Cyprinus carpio*) or goldfish (*Carassius auratus*; Finger, 1983b, 1987; Lamb and Finger, 1995; Osse *et al.*, 1997); benthivorous species which locate food with well-developed, taste bud-laden barbels and large facial lobes, e.g. the gudgeon (*Gobio gobio*) and stone loach (*Nemacheilus barbatulus*); visually orientated predators of mainly small invertebrates with fairly small vagal and facial lobes, e.g. roach or chub (*Leuciscus cephalus*); and the plankton- and surface-feeding bleak, where acoustic areas are large and facial and vagal lobes are relatively small (Fig. 6). In addition to this early work, relationships between life style and cyprinid brain structure have been considered in several, largely qualitative, contributions (Evans, 1931, 1932; Schnitzlein, 1964; Davis and Miller, 1967; Rao, 1967; Singh, 1972; Branson, 1979; Bhatt and Singh, 1980, 1984; Masai *et al.*, 1982). More recently, quantitative data sets have become available for several cyprinid lineages and the characteristics of the underlying trends have been identified by multivariate statistical analysis.

Comparative quantitative histology for 16 brain areas in 14 (Kotrschal and Junger, 1988) and 28 (Kotrschal and Palzenberger, 1992) species of mid-European cyprinids showed the highest amount of variability in the primary sensory lobes processing taste, followed by acoustic and lateral line centres. Interspecific heterogeneity was intermediate in optic lobes and olfactory bulbs, while the telencephalon varied little in size. Five groups of cyprinid brain types were distinguished (Fig. 6).

1. The majority of species, including roach, rudd (*Scardinius erythrophthalmus*) and the leuciscines (dace, chub, etc.), feed on a broad spectrum of items and mostly occupy mid-water (Schiemer, 1985, 1988). Their brains feature well-developed visual centres, but taste and lateral line centres of only moderate size. An analysis of retinal and tectal histology indicated that the piscivorous asp may be a visual specialist for the detection of fast-moving objects (Douglas and Hawryshyn, 1990; Kotrschal *et al.*, 1991; Zaunreiter *et al.*, 1991).
2. Seven species were taste-orientated (Fig. 6) with strongly developed taste centres of the brain stem, a large valvula cerebelli, and moderate-size lateral line and visual centres. Bottom-dwelling detritivores and invertebrate feeders such as common carp, tench (*Tinca tinca*) and barbel (*Barbus barbus*) are typical representatives.
3. Five species with ‘abramine’ brains ranged from predominant planktivores, such as blue bream (*Abramis ballerus*) to bottom feeders, such as vimba (*Vimba vimba*). Brains were characterized by well-developed lateral line and visual centres and a reasonable-size facial lobe (Fig. 6).
4. A group of three species, the surface- and plankton-feeding sabre carp (*Pelecus cultratus*), shemaya (*Chalcalburnus chalcoides*) and bleak, was characterized by formidable lateral line and visual lobes, but only small brain stem taste lobes.
5. European minnow (*Phoxinus phoxinus*), feeding largely on an invertebrate diet, has well-developed visual and taste centres and was classified as a separate group.

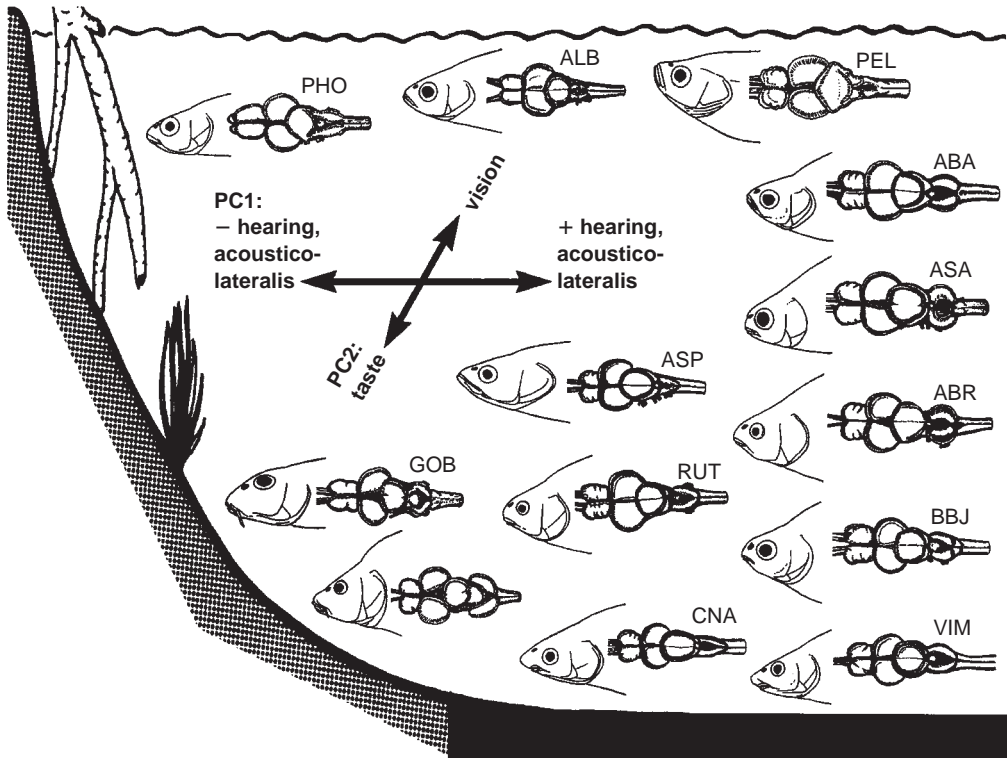

Fig. 6. Summary diagram of the ecomorphological relationships in mid-European cyprinid brains. Brain structure covaries with niches (habitat and feeding). Five groups were identified along the two major axes by principal components analysis, based on quantitative histology in 34 species, PCA axis 1 represented acoustico-lateralis and axis 2, taste–vision. Thus, groups are distinct by the relative volumes of brain stem sensory lobes and of the optic centre (TO). A majority of generalized species is represented here by the omnivorous roach (RUT: *Rutilus rutilus*), by the piscivorous asp (ASP: *Aspius aspius*) and by the benthivorous nase (CNA: *Chondrostoma nasus*). Chemosensory (taste-) brains of benthivores are represented by common carp (CYP: *Cyprinus carpio*) and by gudgeon (GOB: *Gobio gobio*). Examples for the acoustico-lateralis group are the surface- and plankton-feeding bleak (ALB: *Alburnus alburnus*) and sabre carp (PEL: *Pelecus cultratus*). A group of abramine brains are characterized by their considerable development of brain stem taste, acoustico-lateralis in visual lobes. In a grade from the mainly planktivorous blue bream (ABA: *Abramis ballerus*) to the mainly benthivorous vimba (VIM: *Vimba vimba*), the relative sizes of the visual lobes decrease, whereas the facial lobes increase in relative size. The small minnow (PHO: *Phoxinus phoxinus*) living in the clear, shallow waters of Alpine and subalpine lakes and creeks was separated from other species by having both large visual and brain stem taste lobes, but only moderately developed acoustico-lateralis lobes. Other abbreviations: ABR, *Abramis brama*; ASA, *Abramis sapa*; BBJ, *Blicca bjoerkna*. Redrawn, partially after Gomahr *et al.* (1992) and Kotrschal and Palzenberger (1992).

Trends in brain structure in the context of environmental factors, such as turbidity, were identified in a radiation of North American shiners (51 species of the genera *Cyprinella*, *Hybopsis*, *Luxilus*, *Lythurus*, *Notropis* and *Pteronotropis*; Fig. 7a; Huber and Rylander, 1992). Visual centres were larger in species inhabiting clear waters, while

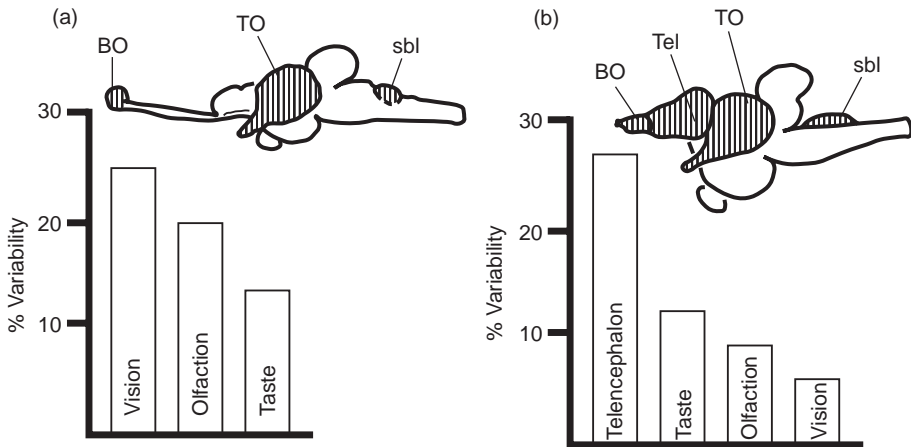

Fig. 7. (a) A quantitative comparison of 51 species of North American shiners (Huber and Rylander, 1992) revealed the olfactory bulb (BO), the optic tectum (TO) and the somatosensory brain stem lobes (sbl) as interspecifically most variable. Species from clear waters had smaller olfactory bulbs and brain stem lobes, but larger optic tecta than species from turbid waters. (b) In 189 species of East African cichlids, an integration centre, the telencephalon (Tel), was interspecifically most variable, followed by the tectum opticum (TO), the primary somatosensory lobes of the brain stem (sbl) and by the olfactory bulb (BO). After van Staaden *et al.* (1995).

olfactory and gustatory structures dominated in species associated with turbid habitats (see also Schellart and Prins, 1993). Olfactory bulbs and cerebellum proved sexually dimorphic, with the former being larger in males and the latter in females. Although the reasons for this dimorphism are unclear, gender differences in pheromone perception may provide an explanation parallel to some cases among deep-sea fishes (Fig. 10). Cluster analysis indicated that both turbidity and shared phylogeny accounted for significant differences in brain morphology.

Concordant with previous work (Herrick, 1902, 1906), both of the aforementioned studies (Huber and Rylander, 1992; Kotrschal and Palzenberger, 1992) identified prominent relationships between the size of primary sensory centres and habitat/feeding styles. These results are also in close agreement with data on gadids (Evans, 1935).

GADIDAE

Gadids rely exclusively on a carnivorous diet, with prey items ranging from small invertebrates to large fish (Fig. 8). The typical brain pattern for this family, exemplified by ecologically generalized cod (*Gadus morhua*), differs from the basic cyprinid design with respect to the arrangement of sensory areas of the dorsal hindbrain (Evans, 1935; Tuge *et al.*, 1968). Paired facial lobes are particularly large in species with barbels or ventral fin appendages (Fig. 8). The lateral line-related cerebellar crest is well developed and reaches its greatest extent in deep-sea species (Macrouridae, Okamura, 1966) or in species taking small epibenthic prey. Optic lobes are large and a prominent corpus cerebelli extends forward where it may even cover the posterior telencephalon.

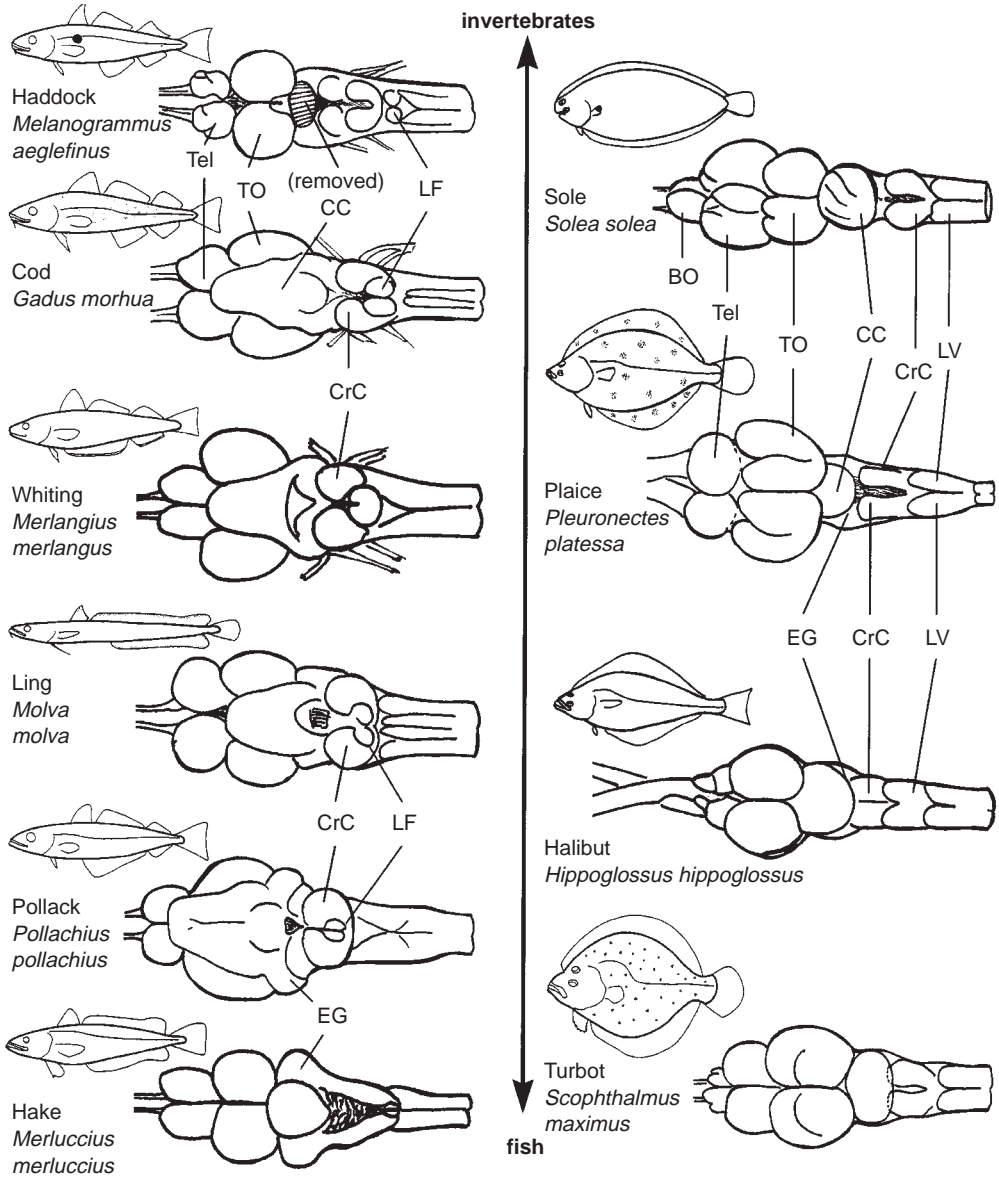

Fig. 8. Both the epibenthic cods and the benthic flatfish contain species that prey to various extents on invertebrates or fish. A qualitative comparison (Evans, 1940) revealed that from the invertebrate feeders to the fish feeders, the optic tectum (TO) and the brain stem acoustico-lateralis lobes (CrC: cerebellar crest and EG: eminentia granularis) increase, whereas the brain stem taste lobes (LF: lobus facialis and LV: lobus vagus) decrease. Note the different brain stems in the cods, as compared with the flatfish, and the olfactory bulbs remote from the telencephalon in the cods. In the flatfish, brain asymmetry affects the olfactory bulbs and the forebrain only. BO, bulbus olfactorius; CC, corpus cerebelli; CrC, crista cerebellaris; EG, eminentia granularis; LF, lobus facialis; LV, lobus vagus; Tel, telencephalon; TO, tectum opticum. Brains redrawn after Evans (1940), habitus redrawn from Lythgoe and Lythgoe (1971).

Diet, and in particular the relative importance of piscivory, determines brain structure in this group (Evans, 1940). Acoustico-lateral areas enlarge and facial lobes gradually diminish in size from haddock (*Melanogrammus aeglefinus*), which feeds exclusively on invertebrates, through cod, whiting (*Merlangius merlangus*), ling (*Molva molva*) and European pollack (*Pollachius pollachius*), to piscivorous hake (*Merluccius merluccius*; Fig. 8). Nocturnal species exhibit smaller optic lobes than predominantly diurnal members. Eyes are frequently large, presumably functioning as photon collectors, as in many mesopelagic fishes (Munk, 1966).

Chemosensory orientation features prominently in mainly night-active rocklings (*Gaidropsarus*, *Ciliata* and related genera), a group of cigar-shaped gadids of the eastern North Atlantic (Lythgoe and Lythgoe, 1971). In addition to barbels bearing a rich aggregate of taste buds, a novel chemosensory structure evolved from the anterior dorsal fin (Kotrschal *et al.*, 1984; Kotrschal and Whitear, 1988). This structure consists of up to 80, small and vibratile fin rays containing up to 100 000 'solitary chemosensory cells' (SCCs) per mm² of epidermis (Kotrschal, 1991, 1996). These cells resemble taste buds in fine structure and are innervated by a set of facial nerve fibres terminating exclusively in a distinct, dorsal portion of the facial lobe (Kotrschal *et al.*, 1984). The ventral facial lobe receives tactile and chemosensory input, particularly from taste buds at the general body surface. Although electrophysiological and behavioural results suggest that, in contrast to taste buds, SCCs are not involved in finding food (summary: Kotrschal, 1996), neuroanatomical evidence still supports the idea that SCCs may be considered a taste subsystem (Kotrschal and Finger, 1996).

FLATFISHES

Symmetrical when young, pleuronectiform teleosts acquire prominent asymmetries only during later development, when they turn to lie either on their left or right body side. Although this change involves a complex modification of head and neural morphology (Finger, 1987, 1988), associated asymmetries in the brain are somewhat less pronounced than expected (Fig. 8). Correspondence between lifestyle and brain organization is evident (Evans, 1937, 1940) and parallels that of gadids. Dietary differences, again ranging from small invertebrates to fish prey, are reflected most notably in the size of olfactory bulbs, optic lobes and taste/acoustico-lateral centres of the brain stem (Fig. 8). This may, however, be too simplistic a view, and brain patterns related to more specific differences in *feeding mode* (e.g. ram versus suction) deserve closer examination.

CICHLIDAE AND OTHER MODERN PERCIFORMS

The generalized cichlid brain follows a typical perciform design (Figs 7, 9 and above), with few obvious specializations at the gross morphological level. Conspicuous though, are well-developed integrative and visual centres (Fig. 7b). Telencephalon, optic tectum, inferior lobes of the hypothalamus and the cerebellum are all relatively large compared with sub-percomorph teleosts (Ridet, 1975; Ridet and Bauchot, 1990a, b), while primary sensory areas for olfaction, acoustico-lateralis, and taste are comparatively small. Individual somatosensory and special viscerosensory columns of the brain stem are difficult to demarcate from the exterior in cichlids as they fail to form separate lobules at the dorsal surface. Cichlids are considered 'microsmathic' with olfactory bulbs barely discernible in most members (Ridet and Bauchot, 1990b). Vision is thus considered the dominant sensory channel in this group, but its importance may be even more

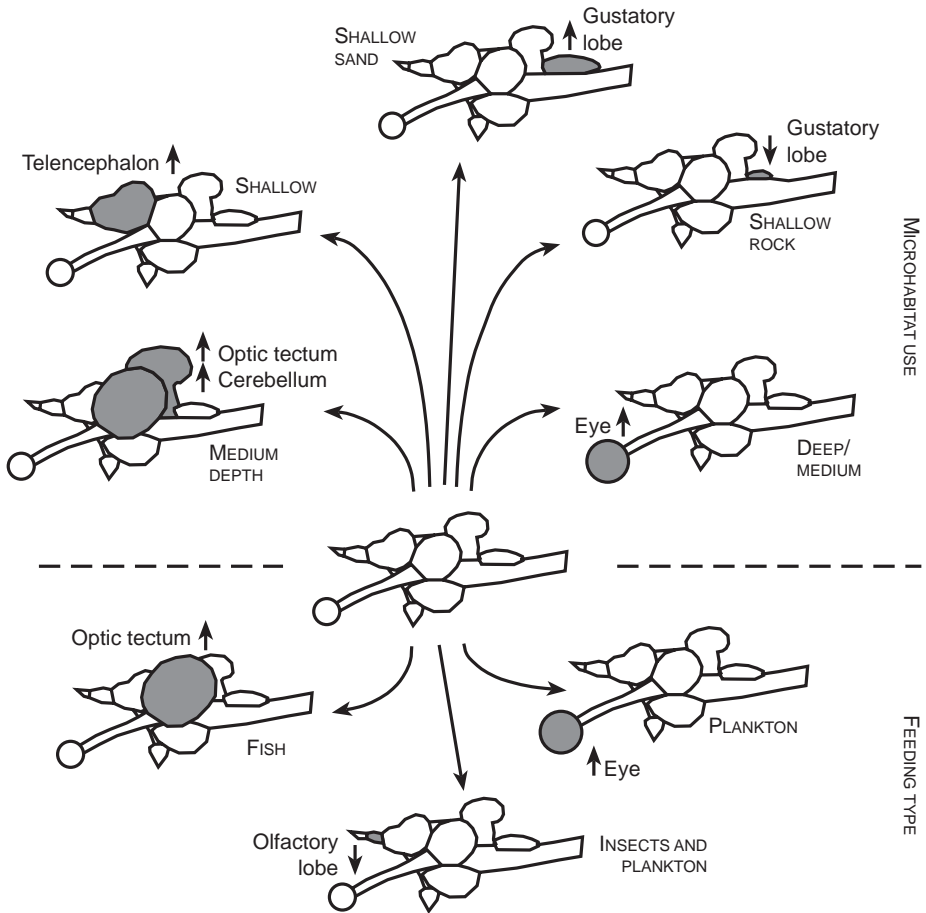

Fig. 9. Evolutionary radiation in East African cichlid brains (compare Fig. 7b) probably started from a generalized brain of shallow-water insectivores. Upward arrow: increasing size. Downward arrow: decreasing size. Relevant parts of the brains highlighted by shading. Specialized feeding styles correlate with modified brains and sensory systems (bottom part of the graph). This is not independent of habitat use, which distinctly affects brain morphology. The forebrain size is significantly larger in shallow rocky reef fishes as compared with all the others. Redrawn from van Staaden *et al.* (1995), Huber *et al.* (1997).

pronounced in some related tropical marine reef fishes, such as blennioids (Bath, 1965), chaetodontids and triggerfish (Collin and Pettigrew, 1988a, b).

Largely independent cichlid radiations in the East African Great Lakes permit brain ecomorphology comparison as a set of evolutionary ‘experiments’ complete with treatment groups and replicates within them (Meyer, 1993; van Staaden *et al.*, 1995; Huber *et al.*, 1997). In all three lakes, feeding strategy and utilization of particular microhabitats are correlated with differences in the size of component brain structures related to particular sensory channels – for instance, improved resolving power with increased eye size in planktivores, superior motion perception through larger optic tecta in species feeding on fish or other fast-moving prey, or enlarged taste centres in species

occupying microhabitats of sandy and muddy substrates (Fig. 9). Preferences for diet, water depth and habitat substrate all proved to be significant correlates of brain structure (Huber *et al.*, 1997).

As reported in other teleost groups, variation of brain structures related to the processing of various sensory channels was significant in cichlids, but was dwarfed by variation in forebrain size (van Staaden *et al.*, 1995; Fig. 7b). Although few of the measured environmental variables explained this association directly, telencephalon size related most closely to the challenges of spatial, environmental complexity (Huber *et al.*, 1997). This interpretation is consistent with data from birds (Riddell and Corl, 1977) and mammals (Clutton-Brock and Harvey, 1980; Jolicoeur *et al.*, 1984), in which the volume of higher centres of processing indicates a species' ability to persist in complex situations, but may also reflect our relative ignorance with respect to cichlid social behaviour.

A comparative, quantitative investigation in 32 species of Antarctic icefish (Notothenoidea; Eastman and Lannoo, 1995) indicates that the cichlid kind of brain variation is not representative for all perciforms. There, olfactory bulbs vary most between species, followed by the eminentia granularis and the crista cerebellaris, which are primary sensory lobes for olfaction and acoustico-lateralis input, respectively.

How environments shape brains: turbidity, benthos and the pelagic realms

The size and shape of brains and their component parts are not only determined by evolutionary history and recent adaptation, but are also profoundly influenced by developmental constraints, for example by allometric growth (Strauss, 1984; Brandstätter and Kotrschal, 1989, 1990; Toyoda and Uematsu, 1994) and somatotopy (Finger, 1982; Kotrschal *et al.*, 1984). On the other hand, size affects prey availability, predation and habitat choice, and particular brains tend to occur in particular habitats.

Brain size itself was found to be a function both of allometric growth (Ridet, 1975; Ridet and Bauchot, 1990a) and of habitat complexity (Bauchot *et al.*, 1977; Huber *et al.*, 1997). In a comparison of individual brain areas, the cerebellum and brain stem nuclei for taste and lateral line usually exhibit positive allometry compared to the olfactory bulb, optic tectum, telencephalon and most other brain areas (Brandstätter and Kotrschal, 1989, 1990).

As is also the case with cichlids, the previously mentioned example of European minnows illustrates that there is no inherent trade-off, or constructional constraint, limiting the growth of individual brain centres (van Staaden *et al.*, 1995; Huber *et al.*, 1997). That is, skull volume is unlikely to impose severe limits on brain size (Fig. 3) except in some of the smallest representatives. Moderate development of optic lobes in fish with large brain stem taste centres may be explained as independent adaptations to the particular (often benthic) environment, where chemosenses and tactile inputs (Kotrschal *et al.*, 1991) outweigh the significance of vision. If in addition to chemosenses, vision is also important, as in the case of clear-water minnows, the optic lobes may enlarge despite the presence of large chemosensory centres.

In general, areas of primary sensory representation tend to relate more closely to feeding (Peter, 1975), whereas higher integration centres reflect differences in microhabitat. These variables are clearly not independent; plankton occurs mainly in the open water, algae on rocks, or burrowing invertebrates in sand and mud. Attempts to separate individual predictors from such complexes are questionable and may even

be of little heuristic value. Out of the entire spectrum of physical stimuli that each particular habitat offers, only a fraction is actually used by any one species or individual, which must be proficient in many aspects, including finding prey, avoiding predators, or recognizing mates. Feeding and predator avoidance are probably most influential in shaping sensory systems, which may secondarily serve as the raw materials to shape sexual dimorphism through sexual selection.

The physical characteristics of any habitat constrain the evolution of sensory and brain structures (Collin and Pettigrew, 1988a, b; Ridet and Bauchot, 1990a, b; Schellart and Prins, 1993). To prey efficiently on plankton at the surface in full daylight presumably represents a different sensory task from doing so at dusk at 15 m depth (Douglas and Hawryshyn, 1990; Guthrie, 1990). The high resolving power needed to feed on small plankton items depends primarily on the number of receptors per visual angle (van der Meer and Anker, 1984; Fernald, 1985; Kotrschal *et al.*, 1990; Zaunreiter *et al.*, 1991). In dim light, thresholds of individual receptor cells may become limiting. Consequently, receptor cells should increase in size to accommodate more membrane, thereby increasing the probability that photons hit the receptor membrane. Keeping the number of receptor cells per visual angle at least constant under such conditions requires still-larger eyes. In close agreement with such theoretical considerations, plankton feeders at moderate light levels often feature exceptionally large eyes (e.g. Holocentridae, Priacanthidae). Lateral line organs, which may serve to draw visual attention to small objects (Bleckmann, 1988; Coombs *et al.*, 1988), are also developed particularly well in plankton-feeding fish.

Reliance on the lateral line sense is increasingly important in open water or at greater depths. Pelagic habitats do not impede the propagation of pressure waves (Denton and Gray, 1988; Coombs *et al.*, 1989) and greater depths exhibit reduced levels of background noise from shore action. Although stimuli decrease in energy with the 3rd power of distance to its source, and travel considerably slower than light, the information is coded in simple parameters such as frequency and amplitude of pressure waves. Pelagic species and most deep-sea fishes represent particular lateral line specialists (Fig. 10), below using this sense to orientate towards prey, or to conspecifics in the contexts of schooling (Coombs *et al.*, 1988, 1989), or in predator avoidance.

Towards the benthos, taste and active/passive electrosenses prevail. Locating an odour source at a distance becomes difficult as information transmitted via chemosensory channels is often complex, sensitivities for individual substances may be high, and dissolved chemicals spread by turbulent flow and diffusion (Atema, 1996). Many species therefore appear to have supplemented chemical perception with other senses such as 'chemosensory touch corpuscles' the taste buds. These allow the precise localization of an odour source which may explain their prevalence in most species of fish (Kotrschal, 1991). Alternatively, olfaction may be well developed in many groups and frequently serves a parallel role in pheromonal communication (see below).

In fish, the relative size of peripheral and central brain centres appears to relate intimately to functional abilities. A comparison of North American minnows in different photic environments evaluated whether the visual system matches increased demand with (1) a larger number of elements, (2) altered characteristics of these elements, or (3) the connectivity between them (Huber and Rylander, 1992). Above all, differences concerned the number of elements. In clear-water species, the retinal area was larger, producing a higher number of retino-fugal nerve fibres, and the volume of

the optic tectum accommodating these fibres was increased compared with species from turbid habitats. No characteristics of individual elements differed noticeably between clear- and turbid-water species, e.g. retinal histology, the distribution of fibre diameters and myelination, and the histology of tectal layers (Huber and Rylander, 1992). Moreover, retinal area closely predicted the number of optic nerve fibres and tectal size, indicating that changes pertained to all components of the visual system in similar proportion.

Although data on sensory structures are provocative and have to date been replicated in several taxa (Snow and Rylander, 1982), doubt remains as to whether such simple and linear patterns may also extend to higher centres of processing. A study on African cichlids indicated that species occupying complex, spatially structured habitats of reed or rock crevices had considerably larger forebrains than those living in two-dimensional habitats over sand or mud flats or pelagic species (Fig. 9; Huber *et al.*, 1997). These findings are similar to those for Hawaiian reef fishes (mainly percomorphs: Bauchot *et al.*, 1977), in which movement within complex 3-D reef structures was paralleled by large brains with forebrain a major contributor, whereas sit-and-wait predators and those relying on crypsis to avoid predation had particularly small brains. These particular patterns may be unrelated to habitat complexity *per se*, but to a correlated complex of social behaviour and species interactions including behavioural parameters of territoriality, pair formation, communication abilities, or visual orientation. In shallow, complex habitats, vision mediates a rapid, accurate and broad comprehension of surrounding information (Lythgoe, 1988) and may thus enhance central integration potentials. The splendidly coloured species, such as cichlids or tropical reef fishes, may utilize these visual and integrative capacities extensively in the social domain (Seehausen *et al.*, 1997).

It remains an open question whether the different radiations of cichlid, notothenoid or cyprinid brains (Eastman and Lannoo, 1995; see above) are due to tighter species packing towards the Equator than in higher latitudes. The idea that social and species interactions at relatively stable environmental conditions determine low-latitude assemblages, and mediate brains which vary comparatively little in primary sensory centres, is supported by Bauchot *et al.* (1989b). Their comparison of 52 species of angelfish (Pomacanthidae) and butterflyfish (Chaetodontidae) revealed relatively uniform brains in these closely related families. However, most species had relatively large forebrains and optic tecta as compared with other perciforms.

The need to elucidate the rules that translate morphological variation into differences in functional performance cannot be overstated. Psychophysical determination of sensory abilities and experiments evaluating competence in cognitive tasks should contribute significantly towards linking form and function. Percomorph tropical marine reef fishes with large brains and forebrains, such as Chaetodontidae or Balistidae (Bauchot *et al.*, 1989a, b), represent prime candidates for such analyses (Fricke, 1975; Kotschal, 1987, 1989), while similar analyses of African cichlids may go a long way in explicating the explosive radiation of this family in the Great Lakes.

Variation of brain and senses with depth

Considerably less ecomorphological data are available in marine fish than in some taxa of freshwater fish. However, it appears that shallow-water reef fishes are visually orientated

and characterized by large brains, featuring well-developed forebrains, optic tecta and cerebella. Particularly revealing are depth gradients among marine fishes (Figs 10, 12). Irrespective of taxonomic group (trichiurid, gempylid, gonostomatid, etc.), vision and lateral line are prominent senses in the shallow pelagic. With increasing depth, light fades and eyes generally become either specialized or reduced, whereas the lateral line grows in importance. As is typical in low-noise environments, the width and placement of lateral line canal systems decrease and they are gradually replaced with free neuromasts (Marshall, 1967a, 1971, 1979; Coombs *et al.*, 1988). An optimization of lateral line input arises when the body becomes increasingly elongated with tapering tails, as in anguillids and mackerel-like trichiurids. The elongated body in these species serves as a long reference line, or 'antenna', to judge direction and distance of vibration sources (Bone *et al.*, 1995). It remains a matter for speculation, however, to what degree the sensory systems of groups dominating the bathypelagic (e.g. the Gonostomatidae or the Opisthoproctidae) were sensorily 'preadapted' to invade the deep sea, or, alternatively, to what extent their parallel sensory orientation developed as an adaptation to specific local selection pressures.

In the mesopelagic (depth <1000 m), olfaction and taste are seemingly of minor relevance. The visual system is optimized for detecting moving contrasts at low light levels and its efficiency in trapping light quanta is enhanced 15–30 fold compared with humans (Marshall, 1971). Large eyes (Fig. 10), lenses and vitreous bodies of exceptional clarity, and retinas containing multiple layers of rod acromeres (Munk, 1966) allow the utilization of residual light from the surface and from abundant bioluminescence. Cerebella are of moderate size in most mesopelagic fishes, even though they are living in a three-dimensional habitat.

The mesopelagic-bathypelagic (at 1000 m) transition (Fig. 10) produces dramatic changes in sensory organs and brains. The brains of most bathypelagic fishes are reduced to an indispensable minimum (*Acanthonus*, Fine *et al.*, 1987) compared with their mesopelagic relatives (Fig. 10; Marshall, 1979). It is likely that this trend results from energy constraints at great depths as brain tissue is particularly costly to maintain. Reductions particularly involve forebrain and cerebellum, the latter probably scaling

Fig. 10. Brains of meso- and bathypelagic fishes (except for the bathybenthic *Synaphobranchus kaupii*). With increasing depth, brains are reduced in size, most notably at the mesopelagic–bathypelagic transition. Mesopelagic fishes emphasize vision, lateral line and hearing, as exemplified by the well-developed tectum opticum, crista cerebellaris and eminentia granularis in *Aphanopus* sp. Two representative species pairs (*Gonostoma denudatum* and *G. bathyphyllum* as well as *Astronethes niger* and *Neoceratias spinifer*) show the overall decrease in size of the brain below 1000 m and the reduction of the visual system. Epibenthic or bathybenthic species in addition feature chemosenses, olfaction and taste, as shown by the series of deep-sea eels from the benthic *Synaphobranchus* to the bathypelagic *Cyema*. Note the general reduction in brain size, and in the sizes of the telencephalon and of the tectum opticum towards the pelagic. In some bathypelagic fishes the size of the olfactory system is sexually dimorphic. As exemplified by *Cyclothone* sp. and *Gonostoma* sp. (bottom), males show a considerably larger olfactory mucosa, olfactory bulbs and a larger telencephalon compared with females. BO, bulbus olfactorius; CC, corpus cerebelli; CrC, crista cerebellaris; EG, eminentia granularis; LF, lobus facialis; LV, lobus vagus; OM, olfactory mucosa; Tel, telencephalon; TO, tectum opticum; TrO, tractus olfactorius. Redrawn after Marshall (1967a, b, 1979), habitus of *Aphanopus* from Nelson (1994).

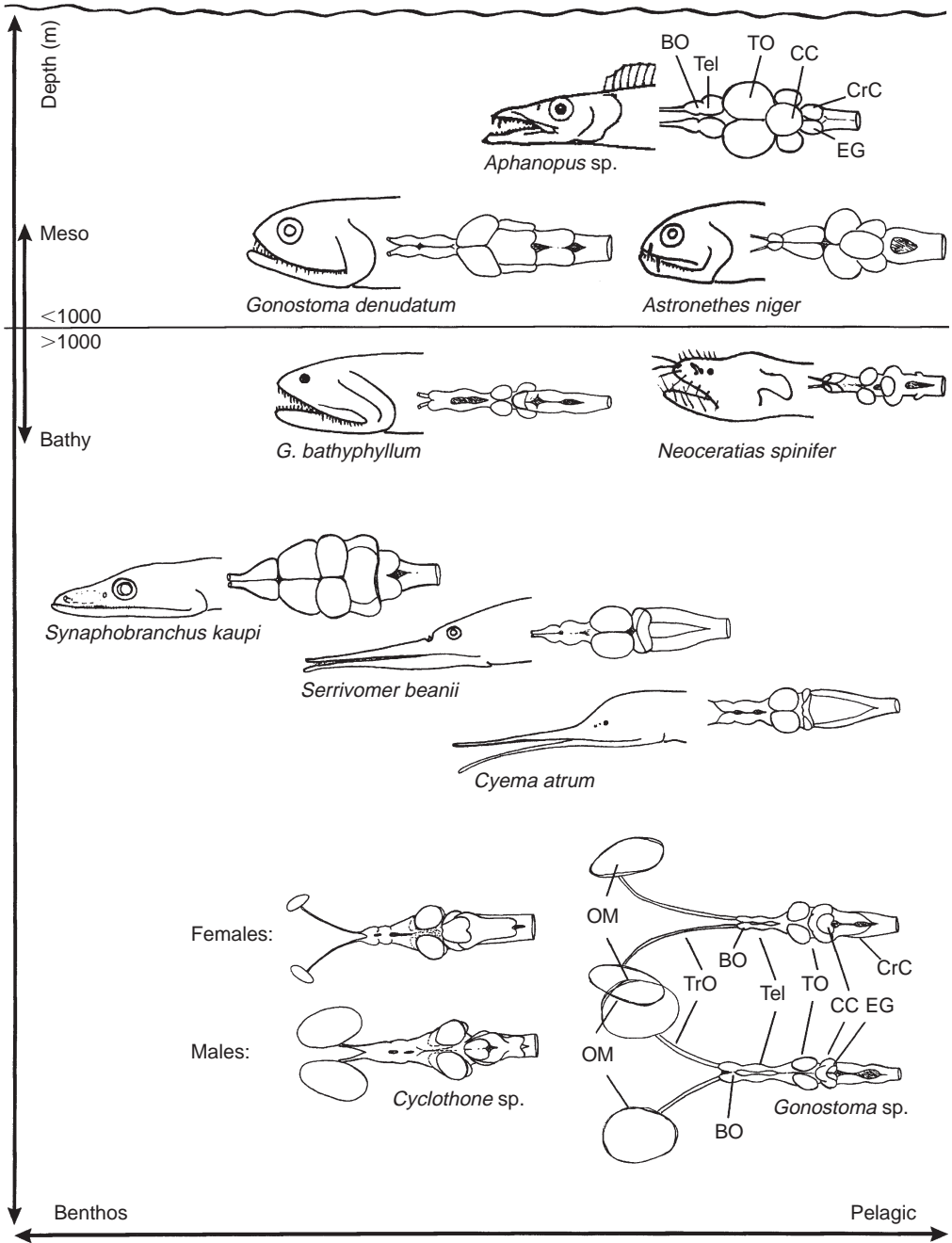

with the loss of trunk muscles. Eyes and accordingly, optic lobes, decreased in most known species but primary acoustico-lateralis centres (eminentia granularis and crista cerebellaris) may be spared from these reductions. In bathybenthic species, external taste and, possibly, tactile systems may be well developed, for example in macrourids, brotulids and morids. At least in the macrourids, which dominate the slopes of the continental shelf, a chemosensory 'preadaptation' towards their bathybenthic habitats cannot be excluded, judging on the grounds of chemosensory orientation of many gadiforms. On the other hand, the grade of bathybenthic to bathypelagic anguilliforms (Fig. 10) suggests that specific habitats may exert strong and specific selection pressures which promote adaptation.

The olfactory complex (mucosa, nerve, bulb, forebrain) of males may be much larger than that of females (Fig. 10) in some species with a low density of mature females, such as *Cyclothone microdon* (Marshall, 1967a, b, 1971) or the ceratoid anglers. The size of the telencephalon varies in parallel with that of olfactory structures (Fig. 10), and the teleurephalon may specialize in perception rather than the emphasis on processing seen in shallow-water reef fishes. Prominent neurons in the rhombencephalic–myelencephalic reticular formation of ceratoid anglerfish (Shanklin, 1935; Waterman, 1948) may mediate swift escape responses, which are probably sufficient and indispensable in such an extreme environment.

Ontogenetic variation: a means of adaptation?

The importance of individual variability during ontogenesis as a source of adaptive fine adjustment in certain environments has been largely ignored. After hatching, larvae are visually orientated planktivores and grow over several orders of magnitude into their adult niches (Fig. 11; Fernald, 1985; Kotrschal *et al.*, 1990). In the earliest developmental stages, teleost fish possess the smallest functional vertebrate brains, with extreme miniaturization of nerve cells compared with amphibians, elasmobranchs, or chondrosteans. The teleost embryonic nervous system, developing from a massive accumulation of cells, may represent yet another adaptation towards functionality at extremely small size. Allometric growth of the brain and its components then fashions, from relatively convergent larval brains, the entire diversity of adult morphologies (Brandstätter and Kotrschal, 1989, 1990; Kotrschal *et al.*, 1991; Toyoda and Uematsu, 1994).

INTRASPECIFIC VARIATION BETWEEN 'ADULT' AGE CLASSES

In fish no final 'adult' morphology can be defined because growth slows but never terminates. Allometric growth causes age-dependent shifts along sensory axes, with intraspecific variation distributed along these shifts and not around a mean as in species with terminal growth. Although psychophysical determination of an animal's functional abilities are rare (review: Douglas and Hawryshyn, 1990), sensory orientation of species will likely accompany such allometric shifts in morphology (Finger *et al.*, 1991). As sensory differentiation should thus be viewed as a lifelong process in fish, it is probably insufficient to define sensory capacities at the species level alone.

INTRASPECIFIC VARIATION WITHIN AGE CLASSES:

Individuals within a cohort differ in traits. If they are raised in identical environments, much of this variation should be hereditary. If sexually produced offspring are spread in

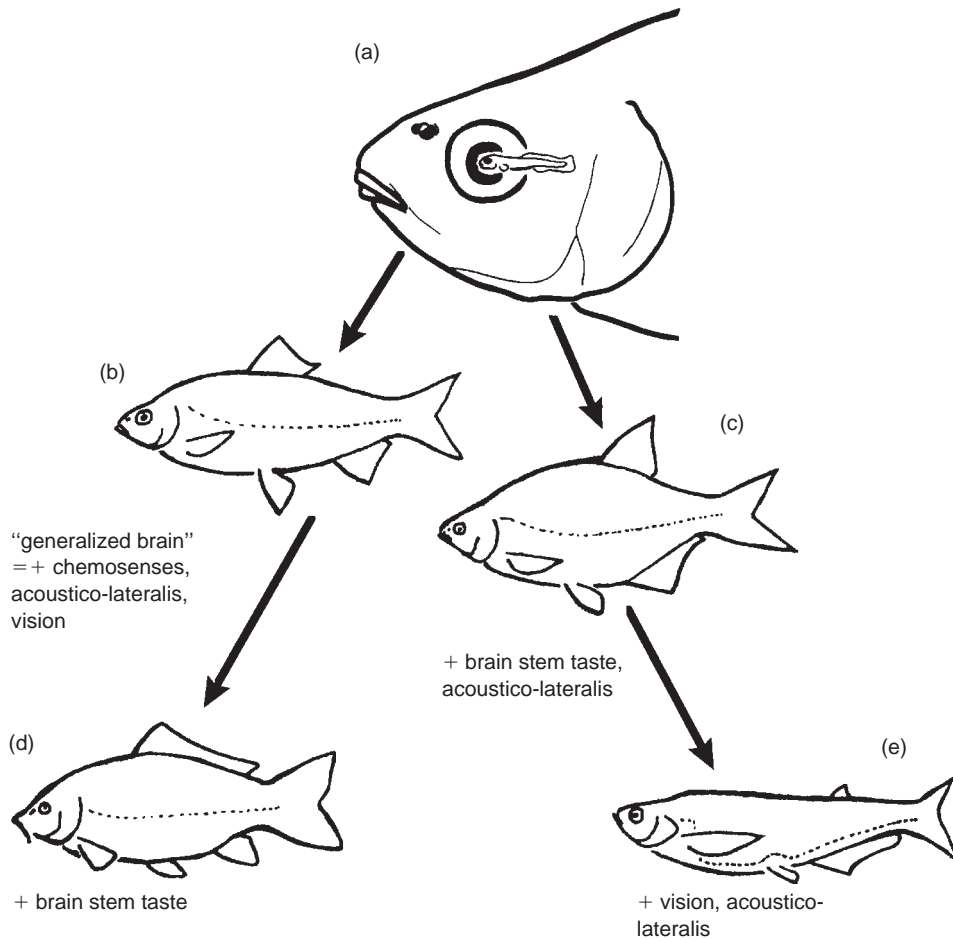

Figure 11. By allometric growth, cyprinids diverge from a relatively uniform, planktivorous larva into generalized (e.g. roach, a, b), abramine (e.g. bream, c), acoustico-lateralis (e.g. sabre carp, e) and chemosensory (e.g. common carp, d) niches and brains (compare Fig. 6). Drawing (a) shows the size difference between a roach larva and an individual 1 year after hatching; the other fish are not drawn to scale. Redrawn from Kotrschal *et al.* (1991).

sufficient numbers, the lotteries of genetic variability and of dispersion will eventually allow that a few individuals choose, or are randomly recruited to, habitats where their genotype provides an optimal fit. In the teleosts with enormous egg numbers, such ‘individual nichification’ would be particularly efficient (Williams, 1975), but there are hardly any data to support this idea. In contrast, if they are raised in different environments, even genetically heterogeneous, sexually produced individuals may show peculiar shifts in morphology. Such shifts may be interpreted as inherent adaptability, possibly eased by the lack of terminal morphological states. Raising two different species of cyprinids in clear and turbid water, for example, had no discernible effect on the development of external taste buds in either nase or roach, but did significantly affect eye

size (Peschel, 1995); brains were not investigated in this case. In both species, eyes of individuals raised in clear water were larger than in their siblings raised in turbid water. Even though the functional meaning of this change remains unclear, it serves to support speculations that the feedback of environmental parameters during ontogeny may allow some flexibility for the individual fine adjustment towards certain environments (Stabell and Maung San Lwin, 1997).

Conclusions: where to go from here?

A variety of patterns have emerged from nearly a century of ecomorphological research on fish brains, beginning with Herrick (1902). Fish from highly structured, shallow-water reefs evolved specialized perceptive and cognitive skills in the context of visual processing, whereas specialized perceptive skills prevail in pelagic species and with increasing depth (Fig. 12). Specific brain anatomies result from phylogenetic inertia (group traditions), transmission properties of the ambient medium and in some specialized cases from energy constraints.

Research focusing on relationships between brains and feeding styles has yielded reasonable correspondence, particularly in groups with specialized perceptive skills (external taste or lateral line), such as the sub-percomorph cyprinids and gadids. The move towards ever finer-grained investigations will probably continue and should increasingly include differences in behavioural parameters such as predator avoidance or social behaviour. It is to be hoped that future comparative research will continue to tackle groups of closely related species differing in body size, habitat utilization (and the threat of predation) or social systems (spawning, territoriality, parenting styles, etc.). Perciforms, particularly cichlids, pomacentrids, embiotocids, labrids, scarids, chaetodontids, acanthurids, or blennioids, represent promising candidate groups for such analyses as they are sufficiently species-rich with a stunning diversity in body size, social organization and lifestyles.

Relationships between brains and lifestyles were somewhat less obvious in perciform fishes, where, in cichlids and butterflyfish, for example, a shift from specialized perception to cognitive skills may have changed the brain into a more flexible apparatus. Visually orientated, 'cognitive' brains with a disproportionate development of large, multimodal integration centres may even be seen as one of the preconditions paving the way for the enormously successful percomorph – particularly perciform – radiation into a plethora of niches.

Ontogenetic variability is yet another area urgently in need of attention. We have just scratched the surface of the question whether, and to what extent, this affects brain and sensory development and thus, in turn, to what extent environmentally induced differences in sensory and brain structure feed back on preferences for certain environments. Fish, where lifelong allometric growth adds a source of variation not available in other vertebrates with terminal growth, embody great potential for both pure and applied research. We need detailed behavioural and (psycho)physiological studies concerning the functions of different brain areas in fish, particularly in an evolutionary context. Moreover, because the current evidence for environmental effects on sensory systems and brains is largely correlative and does not permit firm conclusions regarding causation, the demand for more experimental investigations is paramount.

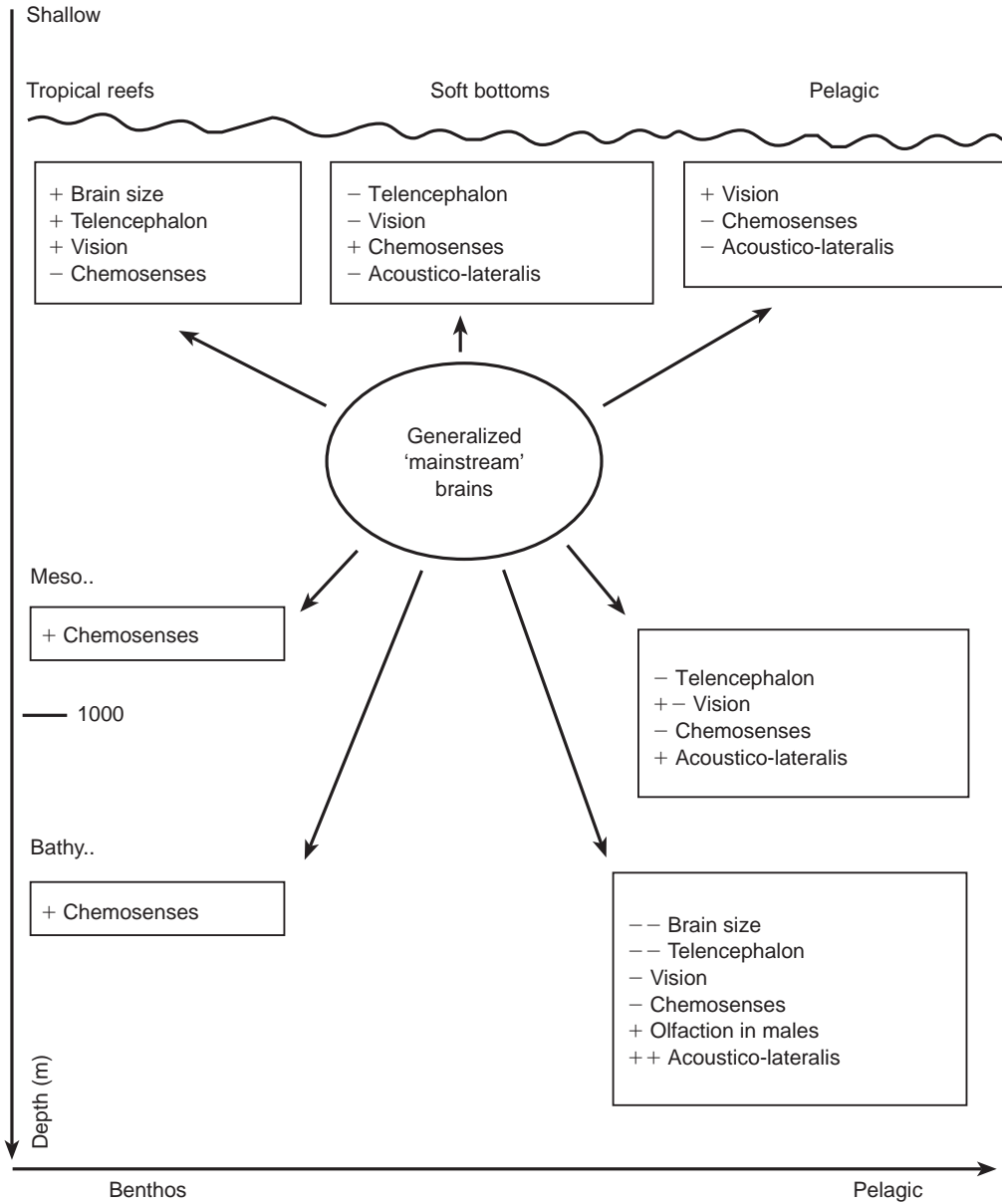

Fig. 12. Summary diagram of the trends by which major habitats may shape fish brains.

Acknowledgements

This review benefited from the critical comments of two anonymous referees. Support was provided by the *Verein der Förderer der Konrad Lorenz Forschungsstelle* and the *Büro für Auslandsbeziehungen*, University of Graz.

References

- Ahlbert, I.B. (1968) The organization of cone cells in the retinae of four teleosts with different feeding habits (*Perca fluviatilis* L., *Lucioperca lucioperca* L., *Acerina cernua* L. and *Coregonus albula* L.). *Arch. Zool.* **22**, 445–481.
- Aldridge, R. and Purnell, M. (1996) The conodont controversies. *TREE* **11**, 463–468.
- Ali, M.A. and Klyne, M.A. (1985) *Vision in Vertebrates*. New York, NY: Plenum Press. 272 pp.
- Allis, E.P. (1897) The cranial muscles and cranial and first spinal nerves in *Amia calva*. *J. Morphol.* **12**, 487–807.
- Ariens Kappers, C.U., Huber, G.C. and Crosby, E.C. (1967) *The Comparative Anatomy of the Nervous System of Vertebrates Including Man*, Vols I–III. New York, NY: Hafner.
- Atema, J. (1996) Eddy chemotaxis and odor landscapes: exploration of nature with animal sensors. *Biol. Bull.* **191**, 129–138.
- Atema, J., Fay, R.R., Popper, A.N. and Tavalga, W.N. (1988) *Sensory Biology of Aquatic Animals*. New York, Berlin: Springer-Verlag, 936 pp.
- Banarescu, P. (1956) Variation du torus longitudinal du cerveau chez les poissons teleosteens. *Comunicarile Academiei Repub. Pop. Rom.*, **6**, 893–899.
- Bath, H. (1965) Vergleichende biologisch-anatomische Untersuchungen über die Leistungsfähigkeit der Sinnesorgane für den Nahrungserwerb, ihre gegenseitige Abhängigkeit und ihre Beziehungen zum Bau des Gehirns bei *Blennius gattorugine* Brunn., *Blennius galerita* L. und *Gobius cruentatus* L., *GM. Z. wiss. Zool.* **172**, 347–375.
- Bauchot, R., Bauchot, M.L., Platel, R. and Ridet, J.M. (1977) The brains of Hawaiian tropical fishes; brain size and evolution. *Copeia* **1/1977**, 42–46.
- Bauchot, R., Diagne, M. and Ridet, J.-M. (1982) The brain of *Photoblepharon palpebratus steinitzi* (Pisces, Teleostei, Anomalopidae). *J. Hirnforsch.* **23**, 399–404.
- Bauchot, R., Diagne, M., Ridet, J.-M. and Bauchot, M.-L. (1989a) The brain of *Rhyacichthys aspro* (Rhyacichthyidae, Gobioidae). *Jap. J. Ichthyol.* **36**, 260–266.
- Bauchot, R., Ridet, J.-M. and Bauchot, M.-L. (1989b) The brain organization of butterflyfishes. In Balon, E.K. and Motta, P.J., eds. *Environmental Biology of Fishes* **25**. Dordrecht: Kluwer Academic Publishers, pp. 205–219.
- Bhatt, J.P. and Singh, H.R. (1980) Brain pattern in *Puntius chinoides* (McClelland) in relation to its feeding habits. *Bioresarch* **1980/4**, 51–53.
- Bhatt, J.P. and Singh, H.R. (1984) Morphometric studies on the brain lobes of three coldwater teleosts. *Indian J. Anim. Sci.* **54**, 560–565.
- Bleckmann, H. (1988) Prey identification and prey localization in surface-feeding fish and fishing spiders. In Atema, J., Fay, R.R., Popper, A.N. and Tavalga, W.N., eds. *Sensory Biology of Aquatic Animals*. New York, NY, Berlin: Springer-Verlag, pp. 619–642.
- Bone, Q., Marshall, N.B. and Blaxter, J.H.S. (1995) *Biology of Fishes*. London: Chapman and Hall, 332 pp.
- Brandstätter, R. and Kotrschal, K. (1989) Life history of roach, *Rutilus rutilus* (Cyprinidae, Teleostei). *Brain, Behav. Evolut.* **34**, 35–42.
- Brandstätter, R. and Kotrschal, K. (1990) Brain growth patterns in four European cyprinid fish species (Cyprinidae, Teleostei): roach (*Rutilus rutilus*), bream (*Abramis brama*), common carp (*Cyprinus carpio*) and sabre carp (*Pelecus cultratus*). *Brain, Behav. Evolut.* **35**, 195–211.
- Branson, B.A. (1979) Observations of the gross anatomy of the olfactory organ and eyes in five genera of American barbeled minnows (Pisces: Cyprinidae). *Southwestern Nat.* **24**, 501–507.
- Braun, C.B. (1996) The sensory biology of the living jawless fishes: a phylogenetic assessment. *Brain, Behav. Evolut.* **48**, 262–276.
- Burr, H.S. (1928) The central nervous system of *Orthogoriscus mola*. *J. Comp. Neurol.* **45**, 33–128.
- Clutton-Brock, T.H. and Harvey, P.H. (1980) Primates, brain and ecology. *J. Zool. Lond.* **190**, 309–323.

- Collin, S.P. and Pettigrew, J.D. (1988a) Retinal topography in reef teleosts. I. Some species with well-developed areas but poorly developed streaks. *Brain, Behav. Evolut.* **31**, 269–282.
- Collin, S.P. and Pettigrew, J.D. (1988b) Retinal topography in reef teleosts. I. Some species with prominent horizontal streaks and high-density area. *Brain, Behav. Evolut.* **31**, 283–295.
- Coombs, S., Janssen, J., and Webb, J. (1988) Diversity of lateral line systems: evolutionary and functional considerations. In Atema, J., Fay, R.R., Popper, A.N. and Tavolga, W.N., eds. *Sensory Biology of Aquatic Animals*. New York, NY, Berlin: Springer-Verlag, pp. 553–594.
- Coombs, S., Görner, P. and Münz, H. (1989) *The Mechanosensory Lateral Line. Neurobiology and Evolution*. New York, NY, Berlin: Springer-Verlag, 724 pp.
- Davis, B.J. and Miller, R.J. (1967) Brain patterns in minnows of the genus *Hybopsis* in relation to feeding habits and habitat. *Copeia* **1(1967)**, 1–39.
- Davis, R.E. and Northcutt, R.G. (eds) (1983) *Fish Neurobiology*. Vol. II. Ann Arbor: The University of Michigan Press.
- Demski, L. and Schwanzel-Fukuda, M. (eds) (1987) The terminal nerve (Nervus terminalis), structure, function and evolution. *Ann. N.Y. Acad. Sci.* **519**, 469 pp.
- Denton, E.J. and Gray, J.A.B. (1988) Mechanical factors in the excitation of the lateral lines of fishes. In Atema, J., Fay, R.R., Popper, A.N. and Tavolga, W.N., eds. *Sensory Biology of Aquatic Animals*. New York, NY, Berlin: Springer-Verlag, pp. 595–618.
- Douglas, R.H. and Hawryshyn, C.W. (1990) Behavioural studies of fish vision: an analysis of visual capabilities. In Douglas, R.H. and Djamgoz, B.A., eds. *The Visual System of Fish*. London: Chapman and Hall, pp. 373–418.
- Eastman, J.T. and Lannoo, M.J. (1995) Diversification of brain morphology in Antarctic notothenioid fishes: basic descriptions and ecological considerations. *J. Morphol.* **223**, 47–83.
- Engström, K. (1960) Cone types and cone arrangement in the retina of some cyprinids. *Acta Zool.* **41**, 277–295.
- Engström, K. (1961) Cone types and cone mosaic in the retina of some gadids. *Acta Zool.* **42**, 227–243.
- Engström, K. (1963) Cone types and cone arrangements in teleost retinae. *Acta Zool.* **44**, 1–65.
- Evans, H.M. (1931) A comparative study of the brains in British cyprinoids in relation to their habits of feeding, with special reference to the anatomy of the medulla oblongata. *Proc. Roy. Soc. Lond.* **108B**, 233–257.
- Evans, H.M. (1932) Further observations on the medulla oblongata of cyprinoids; and a comparative study of the medulla of clupeoids and cyprinoids with special reference to the acoustic tubercles. *Proc. Roy. Soc. Lond.* **111B**, 247–280.
- Evans, H.M. (1935) The brain of *Gadus*, with special reference to the medulla oblongata and its variations according to the feeding habits of different Gadidae – I. *Proc. Roy. Soc. Lond.* **117B**, 367–399.
- Evans, H.M. (1937) A comparative study of the brains in pleuronectidae. *Proc. Roy. Soc. Lond.* **122B**, 308–343.
- Evans, H.M. (1940) *Brain and Body of Fish. A Study of Brain Pattern in Relation to Hunting and Feeding in Fish*. London: The Technical Press Ltd. 164 pp.
- Fernald, R.D. (1984) Vision and behavior in an African cichlid fish. *Am. Scientist* **72**, 58–65.
- Fernald, R.D. (1985) Growth of the teleost eye: novel solutions to complex constraints. *Env. Biol. Fishes* **17**, 113–123.
- Fine, M.L., Horn, M.H. and Cox, B. (1987) *Acanthonus armatus*, a deep-sea teleost with a minute brain and large ears. *Proc. Roy. Soc. Lond.* **230B**, 257–265.
- Finger, T.E. (1980) Nonolfactory sensory pathway to the telencephalon in a teleost fish. *Science* **210**, 671–673.
- Finger, T.E. (1982) Somatotopy of the representation of the pectoral fin and free fin rays in the spinal cord of the sea robin, *Prionotus carolinus*. *Biol. Bull. Mar. Biol. Lab. Woods Hole* **163**, 154–161.

- Finger, T.E. (1983a) Organization of the teleost cerebellum. In Davis, R.E. and Northcutt, R.G., eds. *Fish Neurobiology*, Vol. I. Ann Arbor: The University of Michigan Press, pp. 261–284.
- Finger, T.E. (1983b) The gustatory system in teleost fish. In Davis, R.E. and Northcutt, R.G., eds. *Fish Neurobiology*. Vol. I. Ann Arbor: The University of Michigan Press, pp. 285–311.
- Finger, T.E. (1987) Gustatory nuclei and pathways in the central nervous system. In Finger, T.E. and Silver, W.L., eds. *Neurobiology of Taste and Smell*. New York, NY: J. Wiley, pp. 331–354.
- Finger, T.E. (1988) Organization of chemosensory systems within the brains of bony fish. In Atema, J., Fay, R.R., Popper, A.N. and Tavolga, W.N., eds. *Sensory Biology of Aquatic Animals*. New York, NY, Berlin: Springer-Verlag, pp. 339–364.
- Finger, T.E., Drake, S.K., Kotrschal, K., Womble, M. and Dockstader, K.C. (1991) Postlarval growth of the peripheral gustatory system in the channel catfish, *Ictalurus punctatus*. *J. Comp. Neurol.* **314**, 55–66.
- Fricke, H.W. (1975) Lösen einfacher Probleme bei einem Fisch. *Z. Tierpsychol.* **39**, 18–33.
- Frumhoff, P.C. and Reeve, H.K. (1994) Using phylogenies to test hypotheses of adaptation: a critique of some current proposals. *Evolution* **48**, 172–180.
- Gage, S.P. (1893) *The Brain of Diemyctylus viridescens, from Larval to Adult Life and Comparisons with the Brain of Amia and Petromyzon*. Ithaca, NY: The Wilder Quarter-Century Book, 313 pp.
- Gomahr, A., Palzenberger, M. and Kotrschal, K. (1992) Density and distribution of external taste buds in cyprinids. *Env. Biol. Fishes* **33**, 125–134.
- Guthrie, D.M. (1990) The physiology of the teleost optic tectum. In Douglas, R.H. and Djamgoz, M.B.A., eds. *The Visual System of Fish*. London: Chapman and Hall, pp. 279–343.
- Heiligenberg, W. (1988) The neuronal basis of electrosensory perception and its control of a behavioral response in a weakly electric fish. In Atema, J., Fay, R.R., Popper, A.N. and Tavolga, W.N., eds., *Sensory Biology of Aquatic Animals*. New York, NY, Berlin: Springer-Verlag, pp. 851–868.
- Herrick, C.J. (1902) The organ and sense of taste in fishes. *Bull. U.S. Fish. Comm.* **22**, 238–272.
- Herrick, C.J. (1906) On the centers of taste and touch in the medulla oblongata in fishes. *J. Comp. Neurol. Psychol.* **16**, 403–439.
- Holmgren, N. and van der Horst, C.F. (1925) Contributions to the morphology of the brain of *Ceratodus*. *Acta Zool.* **6**, 51–165.
- Huber, R. and Rylander, M.K. (1992) Brain morphology and turbidity preference in *Notropis* and related genera (Cyprinidae, Teleostei). In Balon, E.K., Wieser, W., Schiemer, F., Goldschmidt, A. and Kotrschal, K., eds. *Environmental Biology of Fishes* **33**. Dordrecht: Kluwer Academic Publishers, pp. 153–165.
- Huber, R., van Staaden, M., Kaufman, L.S. and Liem, K.F. (1997) Microhabitat use, trophic patterns and the evolution of brain structure in African cichlids. *Brain, Behav., Evolut.* **50**, 167–182.
- Ito, H. (1978) A catalogue of histological preparations of the teleost brains. *Med. J. Osaka Univ.* **28**, 219–228.
- Ito, H. and Kishida, R. (1978) Afferent and efferent fiber connections of the carp torus longitudinalis. *J. Comp. Neurol.* **181**, 465–476.
- Johnston, J.B. (1901) The brain of *Acipenser*. A contribution to the morphology of the vertebrate brain. *Zool. Jahrb.* **15**, 59–260.
- Jolicœur, P., Pirlot, P., Baron, G. and Stephan, H. (1984) Brain structure and correlation patterns in Insectivora, Chiroptera and primates. *Syst. Zool.* **33**, 14–29.
- Kanwal, J.S. and Finger, T.E. (1992) Central representation and projections of gustatory systems. In Hara, T.J. ed., *Chemoreception in Fishes*. New York, NY: Elsevier, pp. 79–102.
- Kassem, M., Ridet, J.M. and Bauchot, R. (1989) Analyse volumétrique des principales subdivisions encéphaliques chez les *Gobioides* (Téléostéens, Perciformes). *J. Hirnforsch.* **30**, 59–67.
- Kishida, R. (1979) Comparative study of the teleostean optic tectum. Lamination and cytoarchitecture. *J. Hirnforsch.* **20**, 57–67.
- Kotrschal, K. (1987) Evolutionary patterns in tropical marine reef fish feeding. *Z. Zool. Syst. Evolut.-forsch.* **26**, 51–64.

- Kotrschal, K. (1989) Trophic ecomorphology in eastern Pacific blennioid fishes: character transformation of oral jaws and associated change of their biological roles. *Env. Biol. Fishes* **24**, 199–218.
- Kotrschal, K. (1991) Solitary chemosensory cells – taste, common chemical sense or what? *Rev. Fish Biol. Fisheries* **1**, 3–22.
- Kotrschal, K. (1996) Solitary chemosensory cells: why do primary aquatic vertebrates need another taste system? *Trends Ecol. Evolut.*, **11**, 110–114.
- Kotrschal, K. and Finger, T.E. (1996) Secondary connections of the dorsal and ventral facial lobes in a teleost fish, the rockling (*Ciliata mustela*). *J. Comp. Neurol.* **370**, 415–426.
- Kotrschal, K. and Junger, H. (1988) Patterns of brain morphology in mid-European cyprinidae (Pisces, Teleostei): a quantitative histological study. *J. Hirnforsch.* **29**, 341–352.
- Kotrschal, K. and Palzenberger, M. (1992) Neuroecology of cyprinids: comparative, quantitative histology reveals diverse brain patterns. In Balon, E.K., Wieser, W., Schiemer, F., Goldschmidt, A. and Kotrschal, K., eds. *Environmental Biology of Fishes* **33**. Dordrecht: Kluwer Academic Publishers, pp. 135–152.
- Kotrschal, K. and Whitear, M. (1988) Chemosensory anterior dorsal fin in rocklings (*Gaidropsarus* and *Ciliata*, Teleostei, Gadidae): somatotopic representation of the ramus recurrens facialis as revealed by transganglionic transport of HRP. *J. Comp. Neurol.* **268**, 109–120.
- Kotrschal, K., Krautgartner, W.-D. and Adam, H. (1983) Crown cells in the diencephalon of *Acipenser ruthenus* (Acipenseridae, Chondrostei). *J. Hirnforsch.* **24**, 655–657.
- Kotrschal, K., Whitear, M. and Adam, H. (1984) Morphology and histology of the anterior dorsal fin of *Gaidropsarus mediterraneus* (Pisces, Teleostei), a specialized sensory organ. *Zoomorphol.* **104**, 365–372.
- Kotrschal, K., Adam, H., Brandstätter, R., Junger, H., Zaunreiter, M. and Goldschmid, A. (1990) Larval size constraints determine directional ontogenetic shifts in the visual system of teleosts. A mini-review. *Z. Zool. Syst. Evolut.-forsch.* **28**, 166–182.
- Kotrschal, K., Brandstätter, R., Gomahr, A., Junger, H., Palzenberger, M. and Zaunreiter, M. (1991) Brain and sensory systems. In Winfield, I.J. and Nelson, J.S., eds. *Cyprinid Fishes, Systematics, Biology and Exploitation*. London: Chapman and Hall, pp. 285–331.
- Kruska, D.C.T. (1988) The brain of the basking shark (*Cetorhinus maximus*). *Brain, Behav., Evolut.* **32**, 353–363.
- Lamb, C.F. and Finger, T. (1995) Gustatory control of feeding behavior in goldfish. *Physiol. & Behav.* **57**, 483–488.
- Laming, P.R. and McKinney, S.J. (1990) Habituation in goldfish (*Carassius auratus*) is impaired by increased interstimulus interval, interval variability, and telencephalic ablation. *Behav. Neurosci.* **104**, 869–875.
- Levine, J.S. and MacNicol, E.F. (1979) Colour vision in fishes. *Scient. Am.* **246**, 108–117.
- Leonhardt, H. (1980) Ependym und circumventrikuläre Organe. In Oksche, A. and Vollrath, L., eds. *Neuroglia I. Handbuch der Mikroskopischen Anatomie des Menschen, Bd. IV: Nervensystem 10*. Berlin: Springer, pp. 176–666.
- Loew, E.R. and Lythgoe, J.N. (1978) The ecology of cone pigments in teleost fish. *Vision Res.* **18**, 715–722.
- Lythgoe, J.N. (1988) Light in the sea. In Atema, J., Fay, R.R., Popper, A.N. and Tavolga, W.N., eds. *Sensory Biology of Aquatic Animals*. New York, NY, Berlin: Springer-Verlag, pp. 57–82.
- Lythgoe, J.[N.] and Lythgoe, G. (1971) *Fishes of the Sea*. Poole, Dorset: Blandford Press, 320 pp.
- Maler, L., Sas, E., Johnston, S. and Ellis, W. (1991) An atlas of the brain of the electric fish *Apteronotus leptorhynchus*. *J. Chem. Neuroanat.* **4**, 1–38.
- Marshall, N.B. (1967a) The organization of deep-sea fishes. *Stud. trop. Oceanogr. Miami* **5**, 473–479.
- Marshall, N.B. (1967b) The olfactory organs of bathypelagic fishes. *Symp. Zool. Soc. Lond.* **19**, 57–70.
- Marshall, N.B. (1971) *Explorations in the Life of Fishes*. Cambridge, MA: Harvard Univ. Press. 204 pp.

- Marshall, N.B. (1979) *Developments in Deep-sea Biology*. Poole, Dorset: Blandford Press. 566 pp.
- Masai, H., Takatsujii, K., Sato, Y. and Ojima, Y. (1982) Morphological variation in crucian brains with special reference to the origin of the goldfish. *Z. Zool. Syst. Evolut.-forsch.* **20**, 296–301.
- Meador, R.G. (1939) The forebrain of bony fishes. *Proc. Kon. Ned. Akad. v. Wetensch., Amsterdam* **42**, 657–670.
- Meyer, A. (1993) Phylogenetic relationships and evolutionary processes in East African cichlid fishes. *TREE* **8**, 279–284.
- Motta, P.J. and Kotrschal, K.M. (1992) Correlative, experimental, and comparative evolutionary approaches in ecomorphology. *Neth. J. Zool.* **42**, 400–415.
- Munk, O. (1966) Ocular anatomy of some deep-sea teleosts. *Dana Rep.* No. **70**, 1–62.
- Nee, S., Read, A.F. and Harvey, P.H. (1996) Why phylogenies are necessary for comparative analysis. In Martins, E.P., ed. *Phylogenies and the Comparative Method in Animal Behavior*. New York, NY, Oxford: Oxford University Press, pp. 399–411.
- Nelson, J.S. (1994) *Fishes of the World* 3rd edn. New York, NY: J. Wiley & Sons, 600 pp.
- Nieuwenhuys, R. (1982) An overview of the organization of the brain of actinopterygian fishes. *Amer. Zool.* **22**, 287–310.
- Nieuwenhuys, R. (1983) The central nervous system of the brachiopterygian fish *Erpetoichthys calabaricus*. *J. Hirnforsch.* **24**, 501–533.
- Nieuwenhuys, R., ten Donkelaar, H.J. and Nicholson, C. (1998) *The Central Nervous System of Vertebrates*, Vols 1-3. Berlin: Springer Verlag, 2219 pp.
- Northcutt, R.G. (1996) The agnathan ark: The origin of craniate brains. *Brain, Behav., Evolut.* **48**, 237–247.
- Northcutt, R.G. and Davis, R.E. (eds) (1983) *Fish Neurobiology*, Vol. I. Ann Arbor: The University of Michigan Press.
- Northcutt, R.G., Neary, T.J. and Senn, D.G. (1978) Observations on the brain of the coelacanth *Latimeria chalumnae*: external anatomy and quantitative analysis. *J. Morph.* **155**, 181–192.
- Northmore, D.P.M., Williams, B. and Vanegas, H. (1983) The teleostean torus longitudinalis: responses related to eye movements, visuotopic mapping and functional relations with the optic tectum. *J. Comp. Physiol. A* **150**, 39–50.
- Okamura, O. (1966) The brain of fishes of the order Gadida, with special reference to its morphological differentiation. *Jap. J. Ichthyol.* **13**, 103–111.
- Osse, J.W.N., Sibbing, F.A. and van den Boogart, J.G.M. (1997) Intra-oral food manipulation of carp and other cyprinids: adaptations and limitation. *Acta Physiol. Scand.* **161** (Suppl. 638), 47–57.
- Pagel, M.D. and Harvey, P.H. (1989) Taxonomic differences in the scaling of brain on body weight among mammals. *Science* **244**, 1589–1593.
- Peschel, P. (1995) Zur ontogenetischen Entwicklung von Sinnessystemen, speziell der externen Geschmacksknospen und der Augen bei Rotauge (*Rutilus rutilus*) und Nase (*Chondrostoma nasus*). Masters Thesis, The University of Vienna. 61 pp.; English summary on p. 55.
- Peter, R.E. (1975) The brain and feeding behavior. *Fish Physiol.* **8**, 121–159.
- Popper, A.N. and Fay, R.R. (1993) Sound detection and processing by fish: critical review and major research questions. *Brain, Behav., Evolut.* **41**, 14–38.
- Rao, P.D.P. (1967) Studies on the structural variations in the brain of teleosts and their significance. *Acta Anat.* **68**, 379–399.
- Riddell, W.I. and Corl, K.G. (1977) Comparative investigation and relationship between cerebral indices and learning abilities. *Brain, Behav., Evolut.* **14**, 305–308.
- Ridet, J.-M. (1975) Étude quantitative de l'organisation et de la variabilité intraspécifique des principales subdivisions encéphaliques chez deux poissons Téléostéens: *Labrus bergylta* Ascanius, 1767, et *Cyprinus carpio* Linnaeus, 1758. *Bull. Mus. Natl. Dohist. Naturelle* **3** **340**, 1369–1389.
- Ridet, J.-M. and Bauchot, R. (1990a) Analyse quantitative de l'encéphale des Téléostéens: caractères évolutifs et adaptatifs de l'encéphalisation. I. Généralités et analyse globale. *J. Hirnforsch.* **31**, 51–63.

- Ridet, J.-M. and Bauchot, R. (1990b) Analyse quantitative de l'encéphale des Téléostéens: caractères évolutifs et adaptatifs de l'encéphalisation. II. Le grandes subdivisions encéphaliques. *J. Hirnforsch.* **31**, 433–458.
- Romer, A.S. (1959) *The Vertebrate Story*. London: The Univ. Chicago Press. 437 pp.
- Romer, A.S. and Parsons, T.S. (1977) *The Vertebrate Body*. Philadelphia: W.B. Saunders. 624 pp.
- Rooney, D.J. and Laming, P.R. (1988) Effects of telencephalic ablation on habituation of arousal responses, within and between daily training sessions in goldfish. *Behav. Neur. Biol.* **49**, 83–96.
- Schellart, N.A.M. (1992) Interrelationships between the auditory, the visual and the lateral line systems of teleosts; a mini-review of modelling sensory capabilities. *Neth. J. Zool.* **42**, 459–477.
- Schellart, N.A.M. and Prins, M. (1993) Interspecific allometry of the teleost visual system: a new approach. *Neth. J. Zool.* **43**, 274–295.
- Schiemer, F. (1985) Die Bedeutung der Augewässer als Schutzzonen für die Fischfauna. *Österr. Wasserwirtschaft* **37**, 239–245.
- Schiemer, F. (1988) Gefährdete Cypriniden – Indikatoren für die ökologische Intaktheit von Flußsystemen. *Natur Landsch.* **63**, 370–373.
- Schnitzlein, H.N. (1964) Correlation of habit and structure in the fish brain. *Am. Zool.* **4**, 21–32.
- Seehausen, O., van Alphen, J.J.M. and Witte, F. (1997) Cichlid fish diversity threatened by eutrophication that curbs sexual selection. *Science* **277**, 1808–1811.
- Senn, D.G. (1976) Brain structure in *Calamoichthys calabaricus* Smith 1865 (Polypteridae, Brachiopterygii). *Acta Zool. (Stockh.)* **57**, 121–128.
- Senn, D.G. (1985) On variation in the brain of bony fishes. *Fortschr. Zool.* **30**, Stuttgart: Gustav Fischer Verlag, pp. 607–610.
- Shanklin, W.M. (1935) VIII—On diencephalic and mesencephalic nuclei and fibre paths in the brains of three deep sea fish. *Phil. Trans. Roy. Soc. Lond.* **224**, 361–419.
- Sibbing, F.A. (1991) Food capture and oral processing. In Winfield, I.J. and Nelson, J.S., eds. *Cyprinid Fishes, Systematics, Biology and Exploitation*. London: Chapman and Hall, pp. 377–412.
- Sibbing, F.A. and Uribe, R. (1985) Regional specializations in the oropharyngeal wall and food processing in the carp (*Cyprinus carpio*). *Neth. J. Zool.* **35**, 377–422.
- Singh, C.P. (1972) A comparative observation of the brain of some Indian freshwater teleosts, with special reference to their feeding habits. *Anat. Anz.* **131**, 234–237.
- Sneath, P.H.A. and Sokal, R.R. (1973) *Numerical Taxonomy*. San Francisco: W.H. Freeman and Co. 573 pp.
- Snow, J.L. and Rylander, M.K. (1982) A quantitative study of the optic system of butterflyfishes (Family Chaetodontidae). *J. Hirnforsch.* **23**, 121–125.
- Stabell, O.B. and Maung San Lwin (1997) Predator-induced phenotypic changes in crucian carp are caused by chemical signals from conspecifics. *Env. Biol. Fish* **49**, 145–149.
- Stell, W.K., Walker, S.E. and Ball, A.K. (1987) Functional-anatomical studies on the terminal nerve projection to the retina of bony fishes. In Demski, L. and Schwanzel-Fukuda, M., eds. *The Terminal Nerve (Nervus terminalis), Structure, Function and Evolution*. *Ann. N.Y. Acad. Sci.* **519**, 80–96.
- Stephan, H. (1967) Zur Entwicklung der Insektivoren nach Merkmalen des Gehirns und die Definition der 'basalen Insektivoren'. *Zool. Anz.* **179**, 177–199.
- Strauss, R.E. (1984) Allometry and functional feeding morphology in haplochromine cichlids. In Echelle, A.A. and Kornfield, I., eds. *Evolution of Fish Species Flocks*. Orono, ME: Univ. Maine Press, pp. 217–230.
- Toyoda, J. and Uematsu, K. (1994) Brain morphogenesis of red sea bream, *Pagrus major* (Teleostei). *Brain, Behav., Evol.* **44**, 324–337.
- Tuge, H., Uchihashi, K. and Sugiura, K. (1968) *An Atlas of the Brains of Fishes of Japan*. Tokio: Tsukiji Shokan Publishing Co., Ltd. 240 pp.
- van der Meer, H.J. and Anker, G.C. (1984) Retinal resolving power and sensitivity to the photopic system in seven haplochromine species (Teleostei, Cichlidae). *Neth. J. Zool.* **34**, 197–209.

- van Staaden, M., Huber, R., Kaufman, L. and Liem, K. (1995) Brain evolution in cichlids of the African Great Lakes: brain and body size, general patterns and evolutionary trends. *Zoology* **98**, 165–178.
- Vigh-Teichmann, I. and B. Vigh (1983) The system of cerebrospinal fluid-contacting neurons. *Arch. Histol. Jap.* **46**, 427–468.
- von Bartheld, C.S. and Meyer, D.L. (1988) Central projections of the nervus terminalis in lampreys, lungfishes and bichirs. *Brain, Behav., Evol.* **32**, 151–159.
- Waterman, T.H. (1948) Studies on deep-sea angler-fishes (Ceratioidea). III. The comparative anatomy of *Gigantactis longicirra*. *J. Morphol.* **82**, 81–149.
- Webb, J.F. and Northcutt, G. (1997) Morphology and distribution of pit organs and canal neuromasts in non-teleost bony fishes. *Brain, Behav., Evolut.* **50**, 139–151.
- Weiger, T., Lametschwandtner, A., Kotrschal, K. and Krautgartner, W.D. (1988) Vascularization of the telencephalic chorioid plexus of a ganoid fish [*Acipenser ruthenus* (L.)]. *Am. J. Anat.* **182**, 33–41.
- Wicht, H. (1996) The brains of lampreys and hagfishes: Characteristics, characters and comparisons. *Brain, Behav., Evolut.* **48**, 248–261.
- Williams, G.C. (1975) *Sex and Evolution*. Princeton, NJ: Princeton University Press. 201 pp.
- Winfield, I.J. and Nelson, J.S. (eds) (1991) *Cyprinid Fishes, Systematics, Biology and Exploitation*. London: Chapman and Hall, 667 pp.
- Winkelmann, E. and Winkelmann, L. (1968) Vergleichend histologische Untersuchungen zur funktionellen Morphologie des Tectum opticum verschiedener Teleostier. *J. Hirnforsch.* **10**, 1– 16.
- Wullimann, M.F. (1994) The teleostean torus longitudinalis: a short review on its structure, histochemistry, connectivity, possible function and phylogeny. *Europ. J. Morphol.* **32**, 235–242.
- Zakon, H. (1988) The electroreceptors: diversity in structure and function. In Atema, J., Fay, R.R., Popper, A.N. and Tavolga, W.N. (1988) *Sensory Biology of Aquatic Animals*. New York, NY, Berlin: Springer-Verlag, pp. 813–850.
- Zaunreiter, M., Junger, H. and Kotrschal, K. (1991) Retinal morphology of cyprinid fishes: a quantitative histological study of the ontogenetic changes and interspecific variation. *Vision Res.* **31**, 383–394.

Accepted 12 August 1998