

# Fifty years of a command neuron: the neurobiology of escape behavior in the crayfish

Donald H. Edwards, William J. Heitler and Franklin B. Krasne

**Fifty years ago C.A.G. Wiersma established that the giant axons of the crayfish nerve cord drive tail-flip escape responses. The circuitry that includes these giant neurons has now become one of the best-understood neural circuits in the animal kingdom. Although it controls a specialized behavior of a relatively simple animal, this circuitry has provided insights that are of general neurobiological interest concerning matters as diverse as the identity of the neural substrates involved in making behavioral decisions, the cellular bases of learning, subcellular neuronal computation, voltage-gated electrical synaptic transmission and modification of neuromodulator actions that result from social experience. This work illustrates the value of studying a circuit of moderate, but tractable, complexity and known behavioral function.**

*Trends Neurosci.* (1999) 22, 153–161

IN 1947, WIERSMA REPORTED that a single action potential in any of the four large axons ('giant fibers' or GFs) that run along the dorsal margin of the crayfish nerve cord caused the crayfish to execute a tail-flip escape response<sup>1</sup>. Wiersma dubbed these the 'command' neurons for escape<sup>2</sup>. Over the ensuing five decades, the circuitry of which these neurons are a part and the behavior that they produce have received intensive study by several laboratories<sup>3–5</sup>. This article reviews briefly both older and newer findings that have been made with respect to this circuitry, with the intent of showing how prolonged and intensive study of one 'simple' system can repeatedly provide insights of general interest that concern both cellular mechanisms and the organization of neural circuitry.

## Circuitry for escape

### *The command-neuron concept*

Wiersma's demonstration that the firing of individual GFs in crayfish could produce a meaningful behavioral response initiated the concept of the 'command' neuron (the idea that single neurons or small sets of neurons could command specific, naturally occurring behavior patterns in response to normal input). Wiersma and subsequent investigators later extended this to other behavioral actions of the crayfish, including the adjustment of abdominal posture, the rhythmic beating of swimmerets and defensive displays<sup>1,6–8</sup>.

The idea of command fibers sparked intense debate<sup>9</sup> and, while there is evidence for command-like systems in other animals<sup>10</sup>, it now appears that animals possess a spectrum of premotor organization. This organization ranges from parallel distributed networks, in which shifts in motor pattern are produced by corresponding shifts in the pattern of activity of a population of premotor interneurons, to command systems, in which categorically different movements are selected and guided by patterns of activity in distinct groups of neurons<sup>11</sup>, and to command neurons themselves. The place on the spectrum occupied by the control system

for a particular behavior probably reflects the degree of flexibility of that behavior. The crayfish escape tail flip is very highly stereotyped and the neuronal system that controls it expresses the organizational principle of the command neuron in one of its simplest forms<sup>12</sup>.

### *The basic circuit*

The escape responses elicited by Wiersma's giant command neurons are rapid bends of the abdomen that thrust the animal through the water, away from the origin of sufficiently abrupt mechanical or visual disturbance. Two forms of escape can be triggered, each by one of the bilateral pairs of command neurons. The medial pair of giant axons (MGs) are activated by stimuli located rostrally and cause bending at all abdominal segments, which thrusts the animal directly backwards; the lateral giant axons (LGs) are activated by sudden caudal stimuli and elicit bending in only the more rostral abdominal segments, which causes the animal to jump upward and rotate its hind end forwards, away from the stimulus<sup>13</sup>. The primary circuitry associated with these neurons is simple (Fig. 1). The LGs receive convergent input from primary afferents and sensory interneurons of the abdomen and make powerful excitatory synapses with giant motoneurons (MoGs), which innervate phasic flexor muscles that will bend the rostral abdominal segments. Correspondingly, the MGs receive input from the head and thorax and excite the MoGs of all abdominal segments, eliciting a uniform abdominal flexion. When the activity in either sensory field is sufficient, the corresponding giant neuron fires (usually only once) and thereby causes the appropriate type of tail flip<sup>13,14</sup>.

This description, which had emerged by about 1975, seemed to explain escape behavior well. However, it had long been known that the GFs recruited another group of motoneurons to the phasic flexor musculature: the fast flexor motoneurons (FFs; Fig. 1). The FFs do appear to enhance the contraction of the fast flexor muscles, but a more essential role for these neurons became

Donald H. Edwards is at the Dept of Biology, Georgia State University, Atlanta, GA, USA, William J. Heitler is at the Gatty Marine Laboratory, University of St. Andrews, Fife, UK KY16 8LB, and Franklin B. Krasne is at the Dept of Psychology and Brain Research Institute, UCLA, Los Angeles, CA, USA.

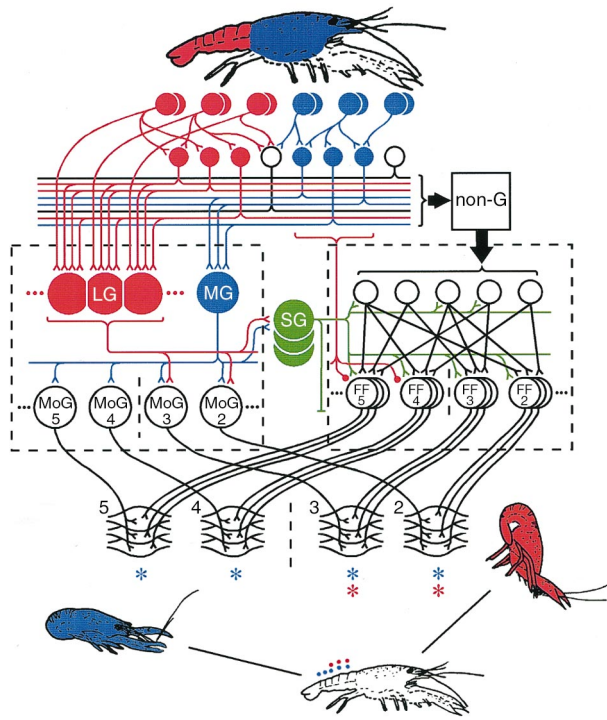

**Fig. 1.** Circuitry for crayfish escape behavior. Giant-fiber (GF)-mediated reactions are portrayed in the drawings at the bottom of the figure<sup>12</sup>: the red crayfish represents a lateral giant-axon (LG)-mediated response and the blue crayfish represents a medial giant-axon (MG)-mediated response. The segmental joints at which bending occurs to produce these reactions are indicated by small colored circles above the white crayfish. LG-associated elements and MG-associated elements are colored in red and blue, respectively. The sensory fields (mechanosensory for LG and mechanosensory and visual for MG) for the two types of GF-mediated reactions are indicated at the top of the figure. Circuitry for GF-mediated responses is shown on the left with primary afferents, sensory interneurons, LG and MG, and giant motoneurons (MoGs) arranged from top to bottom. The multisegmental nature of the LG, which is an electrically well-coupled chain of segmental neurons, each with its own dendrites, is indicated. Colored asterisks mark phasic flexor muscles of segments 2–5 that are used in each type of GF reaction. Circuitry for responses that do not use giant neurons (non-G responses) is shown on the right. A separate population of fast flexor (FF) motoneurons generates non-G responses; uncharted circuitry (box marked non-G) and a set of partially identified pre-motor interneurons (open circles) mediate between sensory neurons and FF motoneurons. The segmental giant neuron (SG; green), with its blind-ending axon, allows the LG and MG to recruit non-G motor and pre-motor units. Lateral giant-neuron-associated sensory circuitry provides inhibitory input to caudal FFs (red) so that the SG will not cause bending at caudal joints during LG-type tail flips. Curly brackets show that multiple neurons of the population innervate the indicated target.

clear when it was learned that the GFs and MoGs only responded to abrupt stimuli<sup>12</sup>. Threats that develop gradually provoke much less prompt forms of escape that involve none of the giant neurons; for these non-giant axon (non-G) responses, the FFs provide the sole path to the musculature<sup>15</sup>. Whereas GF-mediated forms of tail flip are stereotyped in form, non-G flips are adjustable and allow animals to produce responses that propel them directly away from an oblique stimulus or towards specific locations. GF-mediated responses are always single flexions, whereas non-G responses occur frequently as swimming sequences in which extension precedes flexion<sup>16</sup>. It is common for a strong stimulus to cause a prompt GF-mediated reaction which is followed by a period of non-G-mediated swimming<sup>13,16</sup>.

Instead of receiving overpowering input from a few premotor interneurons (the LGs and MGs), as do the MoGs, the FFs receive modest input from a large pool of premotor interneurons. Each premotor interneuron is thought to have distinct output connections and recruitment of the FFs during non-G-mediated escape depends on repetitive firing of many premotor interneurons, whose exact mix of activity seems to determine the form of the flexible motor response<sup>15</sup>. In contrast to GF-mediated responses, whose latency to motoneuron discharge is only a few milliseconds, non-G-mediated responses require many tens of milliseconds for their initiation<sup>13,16</sup>. The relationship between the GF and non-G circuitry is asymmetrical: the non-G circuitry provides no excitatory input to the GF circuitry but the GFs recruit many elements of the non-G network via a single pair of segmental neurons, the segmental giant neurons (SGs).

The contrast between these two mechanisms that elicit phasic abdominal flexion movements is striking. Recruitment of FFs during non-G-mediated escape is reminiscent both of the parallel distributed processing networks of computational theory<sup>17</sup> and of the way that vertebrate eye and limb movements and leech local bending movements appear to be organized<sup>18,19</sup>. In contrast, the recruitment of the MoGs during GF-mediated escape uses what theorists call 'localist'<sup>17</sup> or non-distributed networks.

Why are such very different approaches used for producing what are, after all, rather similar movements of the same muscles? The answer might lie in the different amounts of neural computation that are needed to produce a highly stereotyped behavior and a very flexible behavior. The GF-mediated localist circuitry is well designed for producing categorically distinct, stereotyped movement patterns. Cephalothorax stimulation that is just above the MG activation threshold will cause a pure MG-mediated rearward tail flip even though abdominal stimulation that is just below the LG activation threshold also occurs, and the reverse pattern will cause a pure LG-mediated somersault tail flip. Because a separate summation point is used for each category of response, their forms will remain distinct even though the patterns of stimulation might be only slightly different. In contrast, non-G circuitry supports a wide range of response patterns and the exact parameters of the response vary, probably largely continuously, as a function of parameters of stimulating events. Many tens of milliseconds appear to be needed to calculate the appropriate escape direction and to organize a pattern of abdominal flexion that will produce the appropriate movement. As more systems are studied, perhaps it will emerge that distributed circuit architectures are used when response properties vary as a continuous function of stimulus parameters and that localist architectures are used when discrete numbers of categorically different responses are to be produced and intermediates would be maladaptive<sup>19</sup>.

### The voltage-gated electrical synapse and coincidence detection

The GFs form large, accessible synapses (the giant motor synapses) on the MoG at the exit of the ganglionic third root of each hemisegment, which make them attractive objects for the study of basic synaptic function. Furshpan and Potter<sup>20</sup> discovered that these synapses

## Box I. Rectifying electrical synapses: mechanisms of coincidence detection

The non-linear voltage sensitivity of rectifying electrical synapses, which are ubiquitous in the tail-flip circuits of crayfish<sup>a-d</sup>, enables the lateral giant axon (LG) to function as a coincidence detector for mechanosensory inputs<sup>e</sup>. It also gives such synapses many of the physiological characteristics normally thought to be unique to chemical excitatory synapses, which include functional polarity, temperature-sensitive synaptic delay and a negative dependence of EPSP amplitude on postsynaptic membrane potential<sup>f-l</sup>.

The intercellular conductance (Fig. 1) increases with a temperature-sensitive delay when the transynaptic voltage has exceeded a threshold value (50 mV in Fig. 1), which allows presynaptic action potentials to drive current into the postsynaptic cell<sup>h-l</sup>. As the presynaptic spike falls below the level of the EPSP, the transynaptic potential reverses, and a small current is driven back through the synapse before the increased conductance falls to zero. The discharge of the postsynaptic cell causes the EPSP to decline quickly from its peak value.

Coincidence detection occurs when presynaptic cells are linked to a postsynaptic cell through voltage-sensitive synapses (Fig. 2). When spikes in two presynaptic neurons are synchronous, they act as one large input and produce a large, phasic EPSP. When two inputs are asynchronous, the depolarization created by the early

input blocks entry of the late synaptic current by (1) reducing the driving force across the synapse and (2) increasing the effective threshold potential of that synapse. The inward current through the late synapse also leaks out from the still-open early synapse and contributes to its outward current. As a result, the asynchronous EPSP is reduced relative to the EPSP elicited by coincident inputs. By contrast, EPSPs produced by voltage-insensitive electrical synapses in response to the same coincident and asynchronous presynaptic spikes are quite similar.

### References

- a Furshpan, E.J. and Potter, D.D. (1959) *J. Physiol.* 145, 289–325
- b Edwards, D.H. et al. (1991) *J. Neurosci.* 11, 2117–2129
- c Heitler, W.J., Fraser, K. and Edwards, D.H. (1991) *J. Comp. Physiol.* 169, 707–718
- d Fraser, K. and Heitler, W.J. (1991) *J. Neurosci.* 11, 59–71
- e Edwards, D.H., Yeh, S.-R. and Krasne, F.B. (1998) *Proc. Natl. Acad. Sci. U. S. A.* 95, 1745–1750
- f Bennett, M.V.L. (1977) in *Cellular Biology of Neurons* (Part 1) (Kandel E.R., ed.), pp. 357–416, Williams and Wilkins
- g Edwards, D.H. (1990) *J. Neurophysiol.* 64, 532–549
- h Giaume, C., Kado, R.T. and Korn, H. (1987) *J. Physiol.* 386, 91–112
- i Jaslove, S.W. and Brink, P.R. (1986) *Nature* 323, 63–65
- j Heitler, W.J. and Edwards, D.H. (1998) *J. Exp. Biol.* 201, 503–513

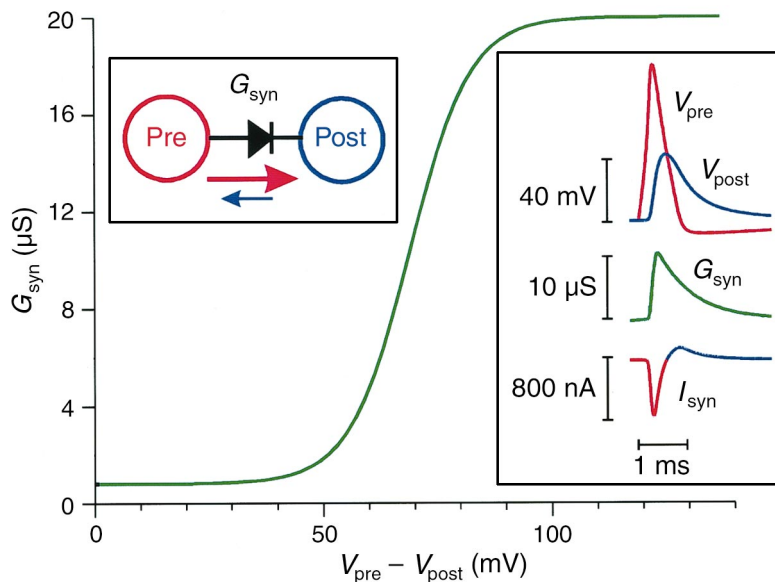

**Fig. 1.** The voltage sensitivity of the transynaptic conductance of a rectifying electrical synapse based on the giant fiber (GF)–giant motoneuron (MoG) junction<sup>h,l</sup>. The conductance of a rectifying electrical synapse (left inset; diode symbol) that links presynaptic and postsynaptic neurons increases sigmoidally as a function of transmembrane voltage (central green curve). When action potentials (right inset; top red trace) make the potential of the presynaptic cell sufficiently positive relative to the postsynaptic cell, synaptic conductance increases (right inset; middle trace), current passes between the cells (right inset; lowest trace: red and blue represent orthodromic and antidromic current, respectively, also indicated by the red and blue arrows in the left inset), and the postsynaptic cell becomes depolarized (right inset; top blue trace). Abbreviations:  $I_{syn}$ , synaptic current;  $G_{syn}$ , synaptic conductance;  $V_{post}$ , postsynaptic voltage;  $V_{pre}$ , presynaptic voltage.

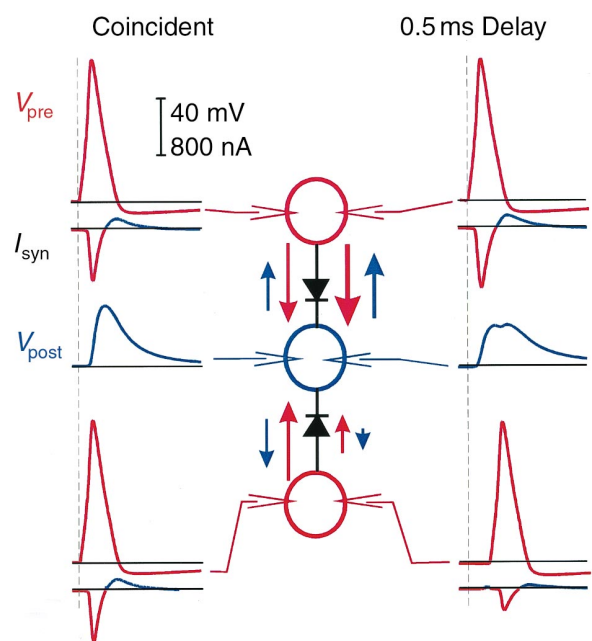
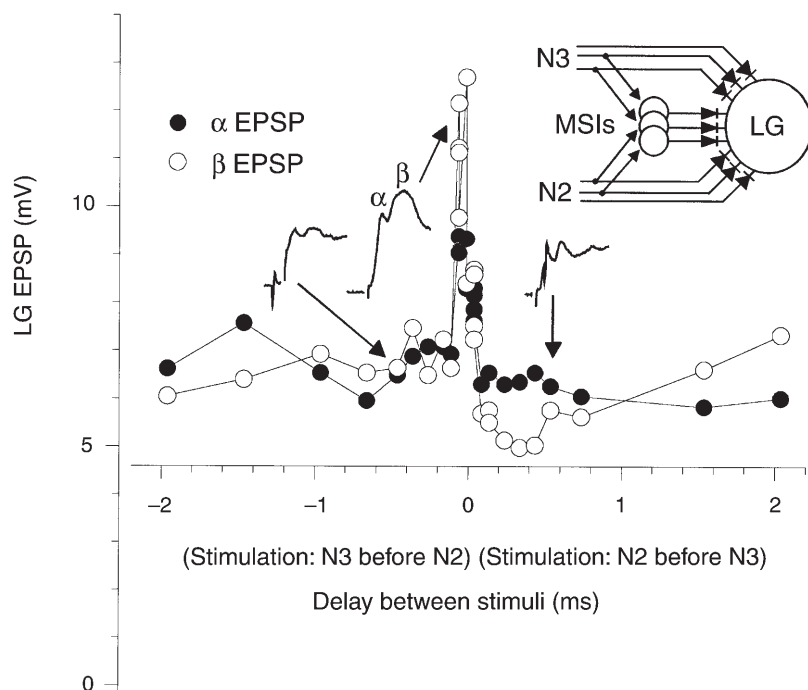

**Fig. 2.** Coincidence detection through rectifying electrical synapses. Two presynaptic cells (red circle) linked to a postsynaptic cell (blue circle; center). Coincident presynaptic spikes are shown on the left and presynaptic spikes 0.5 ms out of synchrony are shown on the right.

passed depolarizing current directly from GFs to MoGs, but not in the reverse direction. It was apparent immediately that this type of synapse provided a fast, unidirectional and highly reliable rectifying electrical connection between giant interneurons and motoneurons. The properties of these junctions give them many of the physiological characteristics that are normally thought to be unique to chemical excitatory synapses (Box 1). Some electrical (but not necessarily rectifying) junctions can even display LTP and LTD (Ref. 21).

It now appears that almost all of the excitatory CNS synapses in Fig. 1, except for the synapses between primary afferents and sensory interneurons, which are cholinergic, are rectifying (that is, voltage-dependent) electrical junctions<sup>20,22–24</sup>. Electrical transmission provides some increases in speed, but it has recently been realized that it has another important consequence: the enhancement of coincidence detection (Box 1).

The prompt escape response produced by GF firing is elicited experimentally by a phasic mechanical tap



**Fig. 2. Coincidence detection at the lateral giant neuron (LG).** The amplitudes (circles) and waveforms (inset) of  $\alpha$  and  $\beta$  EPSPs elicited in the LG by stimulating nerves 2 (N2) and 3 (N3) of the terminal abdominal ganglion (inset).  $\alpha$  EPSP is the first depolarizing wave of the compound EPSP and results from convergence of monosynaptic inputs from primary afferents.  $\beta$  EPSP results from convergence of inputs from mechanosensory interneurons excited by the primary afferents. The EPSPs are largest when the delay between stimulation of N2 and N3 is minimal. Abbreviation: MSI, mechanosensory interneuron.

that excites mechanoreceptors across extended regions of the body almost simultaneously<sup>25</sup>, which emulates the sudden attack of a predator. More gradual stimuli, responses to which are less urgent, tend to cause a ragged volley of sensory activity that fails to recruit the GFs but that can elicit the delayed, but more flexible, non-G-mediated escape. Although several mechanisms have been found to detect the coincident mechanosensory volley that precedes an attack<sup>26</sup>, the intrinsic properties of the voltage-dependent, rectifying electrical synapses that converge onto the LG contribute significantly by attenuating inputs that arrive as little as 100  $\mu$ s out of synchrony (Fig. 2)<sup>27</sup>.

Coincidence detection is important in the nervous systems of many animals<sup>28</sup> for tasks as diverse as localizing the direction of a sound source<sup>29,30</sup>, binding the codes for disparate aspects of a given object<sup>31</sup> and controlling Hebbian changes in synaptic strength during both development and learning<sup>32</sup>. Rectifying electrical synapses might contribute to some of these instances of coincidence detection, as electrical synapses might be more common than usually supposed<sup>33</sup>; recent anatomical evidence suggests that between 30 and 90% of all excitatory synapses in adult mammalian spinal cord include gap junctions<sup>34</sup>.

#### A circuit that anticipates the multiple consequences of its own effects

The firing of the giant axons has a host of non-motor actions, which are obviously necessary in retrospect but far from anticipated, that help us appreciate the sophistication necessary in the design of the circuitry for even the simplest of behavioral actions:

(1) The first such GF-mediated action to be discovered was the inhibition of extensor-muscle stretch

receptors, which prevents extensor-muscle resistance reflexes (which are useful in other contexts) from interfering with the abrupt and powerful tail flexion<sup>35</sup>. This inhibition of proprioceptor firing was one of the earliest, and still most compelling, examples of the once-doubted ability of the nervous system to control the sensitivity of its own input lines. Study of this inhibition also had a seminal role in research on the nature of postsynaptic inhibition (see below). Stretch-receptor inhibition is timed to stop when the abdomen is fully flexed, which leaves the receptors free to produce a strong response to the stretch that is imposed by the completed flexion. This excites abdominal extensor motoneurons and, together with exteroceptive reafference that results from the flexion movement, causes re-extension of the abdomen<sup>16</sup>. Thus, re-extension after GF-mediated tail flips is a chain reflex rather than a centrally programmed part of the motor score.

(2) Each GF also drives inhibition of both the GFs and the MoGs (Refs 3,20,36). This 'recurrent' and 'feed-forward' inhibition ensures that only one or a few GF spikes and only one MoG spike will occur in response to the strongest stimuli, which makes the strength and duration of the abdominal flexion largely independent of stimulus intensity<sup>36</sup>.

(3) The GFs curtail their own inputs additionally by inhibiting the terminals of the mechanosensory afferents presynaptically and by inhibiting sensory interneurons that excite the GFs postsynaptically<sup>37–40</sup>. The inhibition at the first synapse will attenuate the reafferent stimulation that occurs as a result of the violent abdominal flexion of escape, thereby blocking both a vicious cycle of perpetual responses and the initiation of a second response before the first is complete. Inhibition of the first synapse and the LGs also attenuates the effects of reafferent stimulation during walking<sup>41</sup>.

The presynaptic component of first-synapse inhibition has another intriguing role: it prevents use-dependent habituation of the mechanosensory input to the tail-flip circuit<sup>40</sup>. The first-order cholinergic synapses from primary afferents to mechanosensory interneurons (Fig. 1) are the site of activity-dependent reductions in synaptic efficacy that contribute to habituation of the tail-flip response (see below). The presynaptic inhibition greatly reduces the extent to which activity-dependent synaptic depression develops, and thereby protects the reflex from habituating to reafferent stimulation produced by rapid movement through the water. This was the first direct demonstration that nervous systems not only regulate their own input but can also modulate their own plastic mechanisms in useful ways.

All of the GF-driven inhibitions are thought to be mediated, at least in part, by  $\text{Cl}^-$  influx through GABA-receptor-linked  $\text{Cl}^-$  channels. Indeed, it was inhibition of the crayfish stretch receptors that Florey first used as an assay in his discovery that GABA was likely to be an inhibitory neurotransmitter<sup>42,43</sup>; confirmation of this came with the demonstration that GABA was released at the crustacean neuromuscular junction<sup>44</sup>. Stretch-receptor inhibition was also used by Kuffler and Eyzaguirre<sup>45</sup> in their early studies of postsynaptic inhibition, which provided our first clear understanding that postsynaptic inhibition works by shunting EPSPs more than by the subtractive action of hyperpolarization.

Depolarizing inhibition was, therefore, theoretically possible and first found to occur in recurrent inhibition of the MoGs and later in the LGs (Refs 20,36). Depolarization also aids inhibition at voltage-dependent electrical synapses because it back biases the junctions, which raises the amount of presynaptic depolarization needed to open them (Box 1). Furthermore, the depolarization itself promotes inhibition by inactivating Na<sup>+</sup> channels and opening K<sup>+</sup> channels<sup>46</sup>. These mechanisms enable depolarizing postsynaptic inhibition to reduce postsynaptic excitability for extended periods without producing post-inhibitory rebound. This is in contrast with hyperpolarizing inhibition, which promotes rebound by removing both Na<sup>+</sup>-dependent inactivation and K<sup>+</sup>-dependent activation.

It seems likely that further consequences of GF firing will be discovered. Indeed, it alters the activity of a first-ganglion neuron (the A1 5-HT cell) that is believed to release 5-HT into the blood, which suggests that firing of the GFs might also have broad neuroendocrine consequences<sup>47</sup>.

### Modulation and plasticity

A major impetus for trying to elucidate full neural circuits for behavior has been the hope of pinpointing sites of learning and other influences that can alter how an animal will respond to a fixed stimulus. The circuit for GF-mediated escape has been used extensively for this purpose.

#### Tonic inhibition

For a behavioral reaction that is commonly thought of as a 'reflex', the occurrence of GF-mediated escape is extraordinarily capricious. A stimulus that on one occasion will cause escape, seems to be ignored on other occasions. Such variability, which is the hallmark of voluntary behavior in higher animals, makes this behavior intriguing. It would be remarkable if the profound variability of GF-mediated escape were an intrinsic property of the simple circuit portrayed in Fig. 1. It was not, therefore, a great surprise when it was found that a variable inhibitory influence ('tonic inhibition') descends into the abdomen from more rostral ganglia and has a major modulatory influence on the excitability of LG-mediated escape behavior<sup>48</sup> (Fig. 3). A variety of specific circumstances that cause a suppression of LG-mediated escape have now been discovered. These include feeding, restraint that hinders effective escape, defense against attack and agonistic interactions with other crayfish, all circumstances that could reduce the desirability or utility of GF-mediated escape<sup>48–50</sup>. In these cases, the inhibition appears to be directed selectively to the command neuron for the behavior, the LG, and unlike inhibition, whose presumed function is to control refference, it does not appear to have any impact on tail-flip sensory processing or motor circuitry<sup>48,49</sup>. This result highlights the utility of neurons that are dedicated to triggering particular behavior patterns as control points for regulating the excitability of those behaviors selectively.

Tonic inhibition can operate for many hours and, thus, might be thought to be the type of modulation that would be implemented by a second-messenger-mediated neurotransmitter action. However, perhaps because it is adaptive for this type of inhibition to be turned on and off rather rapidly, tonic inhibition in fact appears to be mediated by stimulation of ligand-gated ion channels by GABA (Ref. 51).

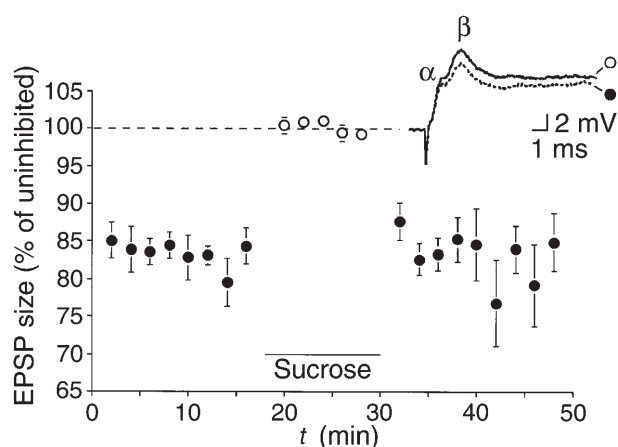

**Fig. 3. Tonic inhibition of the lateral giant neuron (LG).** Interruption of impulse traffic into the abdomen from rostral ganglia, caused by cord severance or sucrose block, removes much of the natural variability of LG-reflex excitability and renders the reflex persistently excitable, which indicates the presence of a variable descending inhibitory influence. Here, EPSPs of the LG were elicited every 2 min by stimulating a sensory nerve in a preparation in which tonic inhibition, caused by restraint, was operative. When conduction into the abdomen was prevented by a sucrose conduction block between the abdomen and thorax (open circles), EPSPs became increased in amplitude due to the removal of inhibition. Sample EPSPs are shown in the upper right of the diagram [inhibited, broken line; during sucrose block, solid line; monosynaptic ( $\alpha$ ) and disynaptic ( $\beta$ ) EPSP components are indicated].

#### Proximal and distal inhibition – gating versus threshold-setting functions of inhibition

The inhibitory synapses of many neurons are located both on distal dendrites near excitatory synapses and proximally where they control spike generation<sup>52</sup>. Unexpectedly, tonic inhibitory synapses were found to be distal, whereas the synapses responsible for recurrent inhibition (already discussed) are located at the proximal site<sup>51</sup>. In retrospect, the differing locations of tonic and recurrent inhibitory innervations make good sense. Proximal inhibition can prevent firing of the LGs regardless of the magnitude of the excitatory input to the dendrites (Box 2); for recurrent inhibition this is adaptive because a new tail-flip response should never begin before an earlier one is completed. By contrast, distal inhibition can always be overridden by sufficiently strong excitation (Box 2). This also seems adaptive because escape threshold should rise during activities like feeding although the LGs should, nevertheless, fire in response to a sufficiently clear threat.

It emerges as a general principle that proximal inhibition is optimal when firing of a neuron needs to be prevented regardless of the magnitude of the excitatory drive. Distal inhibition is the mechanism of choice when excitation and inhibition must compete on relatively equal terms, with each capable of overriding the other. Such competition must occur, for example, during enhancement of contrast by lateral inhibition, and it is routinely assumed computationally in models that use dynamic thresholds<sup>53</sup> and in many parallel distributed processing models<sup>17</sup>.

#### Bases of behavioral habituation

The LG-mediated reaction is quite prone to habituation, as are most escape behaviors. One of the first benefits that arose from the description of its circuitry was the opportunity to determine what type of change was responsible for this simple form of learning. Together

## Box 2. The difference between proximal and distal inhibition

Inhibitory synapses responsible for tonic inhibition are located distally among the excitatory synapses of the lateral giant neurons (LG), whereas the inhibitory synapses responsible for recurrent inhibition are located proximally near the spike-initiating zone of the LG (Fig. 1). When excitatory and inhibitory synapses are close to one another, as in the case of tonic inhibition, each type of input will move local membrane potential towards its own reversal potential and will succeed insofar as it creates a larger post-synaptic conductance change. Therefore, added excitation can always overcome a fixed level of distal inhibition and vice versa. However, proximal inhibition that is applied distant from the site of synaptic excitation, between that site and the spike-initiating zone of the neuron, cannot necessarily be overridden by stronger excitation. In this case inhibition works by shunting the current spreading towards the spike-initiating zone to ground. If inhibition is great enough to prevent spike initiation when the membrane potential local to excitatory synapses has been driven to the excitatory reversal potential, additional increases of excitatory conductance will have no additional effect.

Another difference between proximal and distal inhibition is that the former necessarily applies equally to all

sources of excitatory input to a neuron, whereas distal inhibition can, in principle, attenuate excitation of particular dendritic branches selectively.

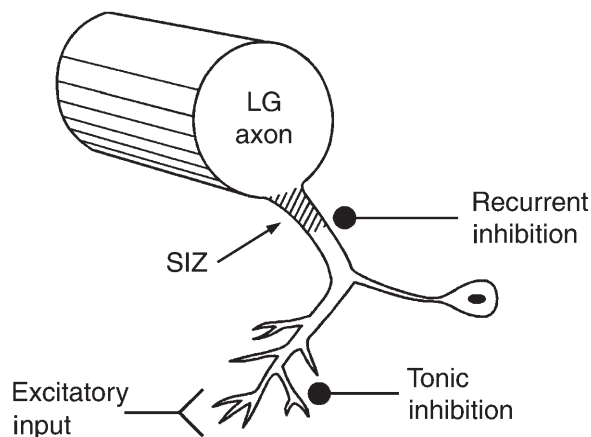

Fig. 1. Location of excitatory and inhibitory input to lateral giant neurons (LG). The spike-initiating zone (SIZ) is shaded.

with the better-known work on *Aplysia*, the analysis of LG-mediated escape has established that habituation results from the intrinsic depression of synapses in the pathway that governs the habituation behavior<sup>4,54</sup>. Quantal analysis then provided evidence that, in both cases, depression results from decreased release of neurotransmitter from chemical synapses: the cholinergic primary-afferent-mechanosensory interneuron synapses in crayfish (Fig. 1)<sup>4,54</sup>, and the primary-afferent-motoneuron synapses in *Aplysia*<sup>55</sup>. These were the first successful attempts made to pinpoint and characterize the changes responsible for any kind of learning, and they were an important origin of the now widely held view that learning occurs as a result of intrinsic alterations of synapses within the circuitry that mediates behavior.

Although it is appealing to attribute a simple type of learning to specific changes at particular synapses, it seems implausible that habituation of a potentially life-saving protective response should be an entirely segmental process in which the brain has no role. More-recent findings suggest that, at least in the crayfish, intrinsic depression of primary-afferent synapses is only part of the explanation; in the behaving animal, habituation is also dependent on GABA-mediated descending tonic inhibitory influences of the type described above<sup>56</sup>. The relationship and possible interactions between intrinsic synaptic change and extrinsic modulation remains an interesting topic for future research.

### Social experience-dependent alterations of neuromodulation

It has been known for some time that 5-HT, which is present at high concentrations in certain crayfish neurons<sup>57</sup> and appears to promote aggressive behavior when applied exogenously<sup>58</sup>, affects the excitability of LG-mediated escape and causes a reduction in the amplitude of EPSPs in the LG (Ref. 59). The natural function of this 5-HT-mediated modulation was

unknown, but depression of escape seemed consistent with promotion of aggression. However, it has been found recently that the effect of 5-HT is not fixed but depends on the social status of the animal tested. When suitably applied, 5-HT decreases the excitability of the LG in socially subordinate crayfish but increases it in dominants or social isolates (Fig. 4)<sup>60</sup>.

Recent experiments that examined the modulation of LG excitability in freely behaving animals have found that during agonistic encounters the excitability of the LG reflex is reduced substantially in subordinates and marginally in dominants<sup>50</sup>. Although it is unclear whether 5-HT is involved, this behavioral modulation shares with the modulation by 5-HT the counterintuitive property that subordinates became less likely to escape than dominants. This paradox is resolved, at least partially, by the discovery that whereas LG-reflex escape is reduced during encounters in the subordinates, non-G-mediated escape is enhanced; this could be because the greater flexibility of non-G escape makes it a more adaptive strategy for the subordinate than the stereotyped reflex escape elicited by the LG neurons.

The discovery that the direct action of a neuromodulator, rather than its availability or release, can be changed by experience is thought to be without precedent. Changes in the effects of the psychoactive modulator, 5-HT, are particularly interesting because they might have implications for the etiology of mental illness, including aggression<sup>61</sup>. It is noteworthy that the inhibitory modulation seen in subordinates can be reversed if a subordinate is paired for several weeks with a new partner to which it is dominant; however, the reverse is not true<sup>60</sup>. Once a crayfish has had extended experience of being dominant, the facilitatory effect of 5-HT seems irreversible (Fig. 4). Reversibility of experience-induced changes in the action of psychoactive neuromodulators, or the lack of reversibility, could have important implications for the treatment of mental disorders.

Experiments with 5-HT-receptor agonists suggest that facilitation and inhibition are mediated by different receptors, and that the differences in the effects of 5-HT in animals of different social status result from different populations of these receptors<sup>60</sup>. The neural or hormonal signals that convey the social status of an animal to the LGs, and also the changes they produce within the cell and the second-messenger cascades that mediate the response to 5-HT, remain to be studied.

### Evolution of the tail-flip circuitry

Most of the synaptic connections found in the 50-year study of the tail-flip circuit make good functional sense (at least with hindsight), but there is an interesting design enigma at the heart of the system, whose explanation could lie in the almost 400-million-year history of the circuit itself. As explained above, the GFs recruit FF motoneurons via interneurons known as the segmental giants (SGs; Fig. 1)<sup>4</sup>. A remarkable feature of the SGs is that they are modified limb motoneurons whose peripheral axons conduct spikes towards segmental appendages, the swimmerets and legs, but end blindly and have no known function<sup>62</sup>. Why does a modified limb motoneuron occur in the middle of a circuit that drives tail flexion?

The explanation for this is likely to be an evolutionary one. Because the most conspicuous and most important consequence (biomechanically) of GF firing is abdominal flexion, it is natural to think of the GFs as premotor to the axial-flexor system, and to assume that this reflects their evolutionary origins. However, another consequence of GF firing is limb promotion<sup>63</sup>,

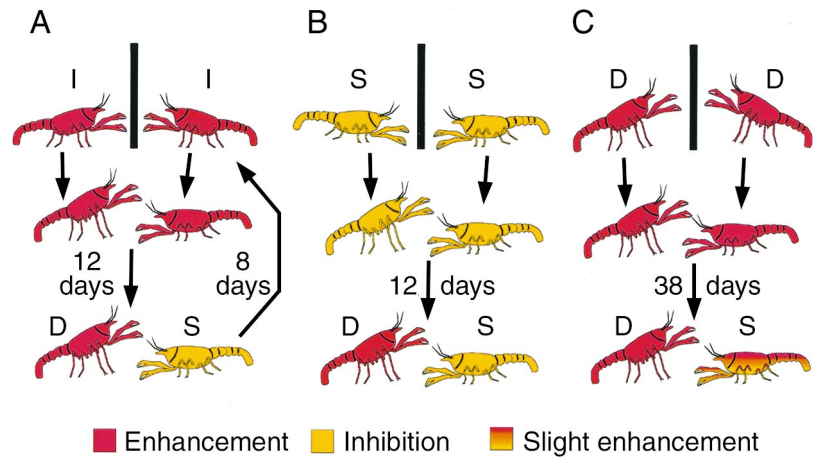

**Fig. 4.** The effect of changes in social status on 5-HT-mediated modulation of lateral giant neuron (LG) excitability. Three types of animals were paired, they fought and established a new dominant-subordinate relationship. After a period of several days together, and again at the stated number of days, they were tested for the effect of 5-HT on LG excitability. Abbreviations: I, social isolate, neutral posture; S, social subordinate, supine posture; D, social dominant, upright posture. (A) I-I pairs; when D and S were re-isolated for eight days, the effects of 5-HT were restored to those of I animals; (B) S-S pairs and (C) D-D pairs. The patterning of the crayfish indicates the effect of 5-HT on LG excitability.

which is caused by powerful monosynaptic connections with limb promotor motoneurons<sup>64</sup>, and this places premotor limb interneurons as legitimate candidate ancestors for the GFs. This suggests an evolutionary path to explain the existence of the SG (Box 3). In this scheme the ancestral escape response was a backwards jump caused by the synchronized protraction of

### Box 3. The possible evolution of the giant tail-flip circuitry

The escape reflex, which arose early in the history of the Eumalacostraca<sup>a,b</sup>, has reached its most elaborate known form in the crayfish. Figure 1 suggests a scheme by which the circuit may have evolved. In this, the segmental giant neuron (SG) acts as an evolutionary 'pivot point' that allowed the behavior to switch from limb-driven to tail-driven. The chief prediction is that the giant fiber (GF)-SG-fast flexor motoneurons (FF) connection preceded the direct GF-giant motoneurons (MoG) connection in the evolution of the circuit. Comparative studies have shown that major adaptive changes certainly do occur within the tail-flip system<sup>c</sup> and although so far none test the main prediction directly, they provide supportive evi-

dence. The anomuran squat lobster *Galathea* shows only non-giant axon (non-G) tail flexions, but the approximate location of the crayfish MoG soma is occupied by the FF with the largest soma and most widespread output distribution<sup>d</sup>, which are characteristics of the MoG. This supports the idea that the MoG evolved from a large but otherwise normal FF motoneuron. The MoG in the hermit crab *Eupagurus* receives strong input from the MG, but also receives input from the SG (Ref. e). This fits the intermediate form postulated by the scheme before the complete loss of the SG-protoMoG connection.

#### References

- a Silvey, G.E. and Wilson, I.S. (1979) *J. Exp. Biol.* 78, 121-136
- b Dahl, E. (1983) in *Crustacean Phylogeny* (Schram, F.R., ed.), pp. 189-212, A.A. Balkema
- c Paul, D.H. (1990) *Frontiers in Crustacean Neurobiology. Advances in Life Sciences*, pp. 537-546, Birkhäuser Verlag
- d Sillar, K.T. and Heitler, W.J. (1985) *J. Exp. Biol.* 117, 257-269
- e Heitler, W.J. and Fraser, K. (1986) *J. Exp. Biol.* 125, 245-269

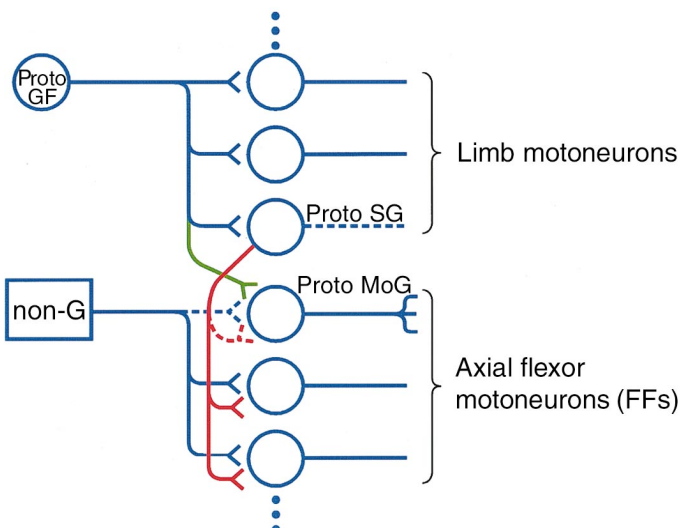

**Fig. 1.** The four possible stages in the evolution of modern giant-fiber (GF) tail-flip circuitry. The conjectural ancestral situation is shown in blue. Later additions are shown in red and green. Elements lost in modern forms are represented by broken lines. First, the ancestral GFs elicited a limb-mediated backward jump in response to threat (blue), as in the modern *Squilla*. Existing axial-flexor motoneurons were driven by non-giant (non-G) interneurons (also blue). Second, a limb motoneuron [the ancestral segmental giant neuron (SG)] established connections to fast flexor motoneurons (FFs) in order to supplement backwards thrust (red). Third, the GFs established a direct connection to the largest FF [the ancestral giant motoneurons (MoG)] as tail flexion became increasingly important (green). Fourth, the SG lost its motor function. The MoG lost all input except that from the GFs (broken lines). Abbreviations: ProtoGF, conjectural ancestral giant fibers; Proto MoG, conjectural ancestral motor giant fibers; Proto SG, conjectural ancestral segmental giant fibers.

segmental appendages, driven by ancestral GFs. As tail flexion is hydrodynamically more effective than limb protraction in producing backward movement, there would have been a selective advantage to incorporating tail flexion in this behavior. If this were achieved by forming connections between a limb motoneuron and the axial-flexor motoneurons in each segment, the situation would be very similar to the GF–SG–FF circuit of the modern crayfish.

The details of the ancestral escape system are necessarily conjectural, but the stomatopod *Squilla* (a mantis shrimp), which diverged from the main malacostracan line leading to modern crayfish very early on, shows a startle response to rostral threat, which consists of a forward thrust of legs and swimmerets that causes a short dart backwards. Furthermore, there is a large-diameter axon in the dorsal nerve cord of this animal that drives limb promotor motoneurons (W. Heitler, unpublished observations). It is not known whether this neuron and behavior are indeed homologs of the crayfish GF system, but they match the proposed ancestral form and confirm its biological plausibility. If the intensity of threat is increased, tail flexion occurs following the limb-mediated retreat, which perhaps indicates the existence of an early non-G-type system.

It is a truism to state that ancestral neural circuits provide the base from which modern circuits evolve, but it is very rare to find clear illustrations of this fact. If the proposed evolutionary scenario is correct, then the occurrence of a limb-related neuron as a link in the middle of a circuit whose main function is tail flexion provides such an illustration. The crayfish nervous system has not left a fossil record of its evolutionary history in stone, but it might have left the SG like a fossil in the layers of the circuit.

### Concluding remarks

One reason for studying invertebrate nervous systems is that, in some cases, the abstract goal of understanding in detail how the nervous system produces behavior seems reachable. However, there are more important reasons. In invertebrates the relatively straightforward connection between neural and behavioral events has enabled us to divine the otherwise obscure functional significance of many neural processes and mechanisms. Discoveries described in this article on presynaptic and on dendritic inhibition illustrate this. Furthermore, although the behaviors studied are specialized and the phyla are alien, invertebrates can provide insights that help us with some of the most difficult questions posed by our own nervous systems. Thus, crayfish escape circuitry has provided insights that might be germane to our understanding of topics as diverse as interactions between neuromodulators and mental illness, mechanisms of learning and mechanisms of perceptual binding. Studies of invertebrate nervous systems have made essential contributions to much of the knowledge that we take for granted; this is a process that can be expected to continue.

### Selected references

- 1 Wiersma, C.A.G. (1947) *J. Neurophysiol.* 10, 23–38
- 2 Wiersma, C.A.G. and Ikeda, K. (1964) *J. Comp. Neurol.* 116, 209–228
- 3 Krasne, F.B. and Wine, J.J. (1987) in *Aims and Methods in Neuroethology* (Guthrie, D.M., ed.), pp. 10–45, Manchester

- University Press
- 4 Wine, J.J. and Krasne, F.B. (1982) in *The Biology of Crustacea Neural Integration and Behaviour* (Vol. 4) (Sandeman, D.C. and Atwood, H.L., eds), pp. 241–292, Academic Press
  - 5 Wine, J.J. (1984) *J. Exp. Biol.* 112, 283–319
  - 6 Atwood, H.L. and Wiersma, C.A.G. (1997) *J. Exp. Biol.* 46, 249–261
  - 7 Bowerman, R.F. and Larimer, J.L. (1976) *Comp. Biochem. Physiol.* 54A, 1–5
  - 8 Kennedy, D., Evoy, W.H. and Hanawalt, J.T. (1966) *Science* 154, 917–919
  - 9 Kupfermann, I. and Weiss, K.R. (1978) *Behav. Brain Sci.* 1, 3–39
  - 10 Grillner, S. (1975) *Physiol. Rev.* 55, 247–304
  - 11 Davis, W.J. and Kennedy, D. (1972) *J. Neurophysiol.* 35, 13–19
  - 12 Olson, G.C. and Krasne, F.B. (1981) *Brain Res.* 214, 89–100
  - 13 Wine, J.J. and Krasne, F.B. (1972) *J. Exp. Biol.* 56, 1–18
  - 14 Mittenthal, J.E. and Wine, J.J. (1973) *Science* 179, 182–184
  - 15 Kramer, A.P. and Krasne, F.B. (1984) *J. Neurophysiol.* 52, 189–211
  - 16 Reichert, H. and Wine, J.J. (1982) *Nature* 296, 86–87
  - 17 Rumelhart, D.E., McClelland, J.L. and the PDP Research Group (1986) *Parallel Distributed Processing: Foundations* (Vol. 1), MIT Press
  - 18 Georgopoulos, A.P. et al. (1989) *Science* 243, 234–236
  - 19 Lewis, J.E. and Kristan, W.B., Jr (1998) *J. Neurosci.* 18, 1571–1582
  - 20 Furshpan, E.J. and Potter, D.D. (1959) *J. Physiol.* 145, 289–335
  - 21 Yang, X., Korn, H. and Faber, D.S. (1990) *Nature* 348, 542–545
  - 22 Watanabe, A. and Grundfest, H. (1961) *J. Gen. Physiol.* 45, 267–308
  - 23 Heitler, W.J., Fraser, K. and Edwards, D.H. (1991) *J. Comp. Physiol.* 169, 707–718
  - 24 Edwards, D.H. et al. (1991) *J. Neurosci.* 11, 2117–2129
  - 25 Newland, P.L., Aonuma, H. and Nagayama, T. (1997) *J. Comp. Physiol.* 181, 103–109
  - 26 Vu, E.T., Berkowitz, A. and Krasne, F.B. (1997) *J. Neurosci.* 17, 8867–8879
  - 27 Edwards, D.H., Yeh, S.-R. and Krasne, F.B. (1998) *Proc. Natl. Acad. Sci. U. S. A.* 95, 1745–1750
  - 28 Konnerth, A. et al., eds (1996) *Coincidence Detection in the Nervous System*, Human Frontier Science Program
  - 29 Hoy, R., Nolen, T. and Brodfuehrer, P. (1989) *J. Exp. Biol.* 146, 287–306
  - 30 Carr, C.E. and Bourdreau, R.E. (1993) *J. Comp. Neurol.* 334, 337–355
  - 31 Singer, W. and Gray, C.M. (1995) *Annu. Rev. Neurosci.* 18, 555–586
  - 32 Hebb, D.O. (1949) *The Organization of Behavior*, John Wiley and Sons
  - 33 Draughn, A. et al. (1998) *Nature* 394, 189–192
  - 34 Rash, J.E. et al. (1996) *Proc. Natl. Acad. Sci. U. S. A.* 93, 4235–4239
  - 35 Eckert, R.O. (1961) *J. Cell. Comp. Physiol.* 57, 149–162
  - 36 Roberts, A. (1968) *J. Exp. Biol.* 48, 545–567
  - 37 Kennedy, D. et al. (1974) *Science* 186, 451–454
  - 38 Kennedy, D. et al. (1980) *J. Neurophysiol.* 43, 1495–1509
  - 39 Kirk, M.D. (1985) *J. Neurophysiol.* 54, 1305–1325
  - 40 Bryan, J.S. and Krasne, F.B. (1977) *J. Physiol.* 271, 351–390
  - 41 Beall, S.P., Langley, D.J. and Edwards, D.H. (1990) *J. Exp. Biol.* 152, 577–582
  - 42 Florey, E. and Biedermann, M.A. (1960) *J. Gen. Physiol.* 43, 509–522
  - 43 Bazemore, A., Elliott, K.A.C. and Florey, E. (1957) *J. Neurochem.* 1, 334–339
  - 44 Otsuka, M. et al. (1966) *Proc. Natl. Acad. Sci. U. S. A.* 56, 1110–1115
  - 45 Kuffler, S.W. and Eyzaguirre, C. (1955) *J. Gen. Physiol.* 39, 589–610
  - 46 Edwards, D.H. (1990) *J. Neurophysiol.* 64, 532–549
  - 47 Horner, M. et al. (1997) *J. Exp. Biol.* 200, 2017–2033
  - 48 Vu, E.T., Lee S.C. and Krasne F.B. (1993) *J. Neurosci.* 13, 4379–4393
  - 49 Krasne, F.B. and Lee, S.C. (1988) *J. Neurosci.* 8, 3703–3712
  - 50 Krasne, F.B., Shamsian, A. and Kulkarni, R. (1997) *J. Neurosci.* 17, 709–716
  - 51 Vu, E.T. and Krasne, F.B. (1993) *J. Neurosci.* 13, 4394–4402
  - 52 Shepherd, G.M., ed. (1998) *The Synaptic Organization of the Brain*, Oxford University Press
  - 53 Marr, D. (1970) *Proc. R. Soc. London Ser. B* 176, 161–234
  - 54 Zucker, R.S. (1972) *J. Neurophysiol.* 35, 638–651
  - 55 Castellucci, V.F. and Kandel, E.R. (1974) *Proc. Natl. Acad. Sci. U. S. A.* 71, 5004–5008

### Acknowledgements

The authors thank the National Science Foundation (of the USA) (D.H.E.) and United States Public Health service (F.B.K.) and the Biotechnology and Biological Sciences Research Council (W.J.H.) for supporting their research.



- 56 Krasne, F.B. and Teshiba, T.M. (1995) *Proc. Natl. Acad. Sci. U. S. A.* 92, 3362–3366
- 57 Real, D. and Czernasty, G. (1990) *Brain Res.* 521, 203–212
- 58 Huber, R. et al. (1997) *Proc. Natl. Acad. Sci. U. S. A.* 94, 5939–5942
- 59 Glanzman, D.L. and Krasne, F.B. (1983) *J. Neurosci.* 3, 2263–2269
- 60 Yeh, S.R., Musolf, B. and Edwards, D.H. (1997) *J. Neurosci.* 17, 680–695
- 61 Edwards, D.H. and Kravitz, E.A. (1997) *Curr. Opin. Neurobiol.* 7, 811–819
- 62 Heitler, W.J. and Darrig, S. (1986) *J. Exp. Biol.* 121, 55–75
- 63 Cook, I.R.C. and Macmillan, D.L. (1985) *J. Exp. Biol.* 118, 351–365
- 64 Heitler, W.J. and Fraser, K. (1989) *J. Comp. Physiol.* 166, 117–124

## Calcium transients and neurotransmitter release at an identified synapse

Philippe Fossier, Ladislav Tauc and Gérard Baux

**It is widely accepted that the modulation of the presynaptic  $\text{Ca}^{2+}$  influx is one of the main mechanisms by which neurotransmitter release can be controlled. The well-identified cholinergic synapse in the buccal ganglion of *Aplysia* has been used to study the modulations that affect presynaptic  $\text{Ca}^{2+}$  transients and to relate this to quantal evoked neurotransmitter release. Three types of  $\text{Ca}^{2+}$  channel (L, N and P) are present in the presynaptic neurone at this synapse. Influxes of  $\text{Ca}^{2+}$  through N- and P-type channels trigger the release of ACh with only N-type  $\text{Ca}^{2+}$  channels being regulated by presynaptic neuromodulator receptors. In addition, presynaptic  $\text{Ca}^{2+}$  stores, via complex mechanisms of  $\text{Ca}^{2+}$  uptake and  $\text{Ca}^{2+}$  release, control the  $\text{Ca}^{2+}$  concentration that triggers this evoked ACh release.**

*Trends Neurosci.* (1999) 22, 161–166

NEUROTRANSMITTER RELEASE occurs in response to the generation of  $\text{Ca}^{2+}$  microdomains under the presynaptic membrane of the nerve terminal. These spatially and temporally localized high concentrations of  $\text{Ca}^{2+}$  induce currently unknown molecular events that permit the translocation of neurotransmitters from the presynaptic nerve terminal to the synaptic cleft. There is a general agreement that the transient rise in  $\text{Ca}^{2+}$  concentration within the nerve terminal is due to the opening of specific voltage-gated  $\text{Ca}^{2+}$  channels and is the main trigger of neurotransmitter. Different types of voltage-gated  $\text{Ca}^{2+}$  channels were identified in neurones according to their pharmacology, to their electrophysiological properties and to their amino-acid sequence<sup>1–3</sup>. This article questions their respective and precise roles in triggering and controlling neurotransmitter release.

To maintain the possibility of neurotransmitter release occurring during repetitive firing of the nerve terminal, the increases in  $\text{Ca}^{2+}$  concentration must be transient and, therefore, significant removal of  $\text{Ca}^{2+}$  from the cytoplasm of the nerve terminal must be achieved between successive presynaptic depolarizations. To recover its resting  $\text{Ca}^{2+}$  concentration, the neurone can either expel  $\text{Ca}^{2+}$ , through its membrane, by using pumps or exchanger mechanisms, or both, or sequester  $\text{Ca}^{2+}$  in organelles by means of a  $\text{Ca}^{2+}$  pump. In the latter case, the organelles must be situated close to the neurotransmitter release sites because the high  $\text{Ca}^{2+}$  concentration (100–200  $\mu\text{M}$ ) that triggers neurotransmitter release is localized to a very small area<sup>4,5</sup>. The possibility that the fast buffering of  $\text{Ca}^{2+}$  in the nerve terminal might have a crucial role in the modu-

lation of neurotransmitter release will also be discussed in this article.

### The role of the different types of presynaptic $\text{Ca}^{2+}$ channel in neurotransmitter release

#### *Modulation of $\text{Ca}^{2+}$ influx by presynaptic receptors*

The roles of the different types of presynaptic  $\text{Ca}^{2+}$  channel have been determined in an identified cholinergic synapse of the *Aplysia* buccal ganglion (Fig. 1) in which measurement of presynaptic ionic currents and quantal evoked neurotransmitter release have been made<sup>6</sup>. At this synapse, the presynaptic  $\text{Ca}^{2+}$  current is due to  $\text{Ca}^{2+}$  influxes through three types of  $\text{Ca}^{2+}$  channel (L, P and N) but only the  $\text{Ca}^{2+}$  influxes through N- and P-type channels trigger ACh release<sup>7</sup> (Fig. 1). Indeed, blocking the L-type  $\text{Ca}^{2+}$  channel with dihydropyridines does not modify neurotransmitter release, which is decreased in the presence of  $\omega$ -conotoxin GVIA or funnel-web-spider toxin<sup>8</sup>. These results show that neurotransmitter release is dependent on more than one type of  $\text{Ca}^{2+}$  channel, that is, the N-type  $\text{Ca}^{2+}$  channel and most probably the P-type  $\text{Ca}^{2+}$  channel<sup>7</sup> (Fig. 1). This characteristic of neurotransmitter release has also been shown in mammalian brain, in hippocampal Schaffer collateral–CA1 synapses<sup>9,10</sup> and at the climbing-fibre synapse between neurones from the inferior olive and cerebellar Purkinje cells in the rat brain<sup>11</sup>. In the peripheral nervous system, the results of Frew and Lundy suggest that neurotransmission in rat urinary bladder is mediated by both N- and Q-type  $\text{Ca}^{2+}$  channels<sup>12</sup>. A recent review by Wu and Saggau<sup>13</sup> describes the different types of  $\text{Ca}^{2+}$  channel involved, alone or in combination, in the release of various neurotransmitters.

Philippe Fossier,  
Ladislav Tauc and  
Gérard Baux are at  
the Laboratoire de  
Neurobiologie  
cellulaire et  
moléculaire  
C.N.R.S., 91198  
Gif sur Yvette  
cedex, France.